

D5-Evo and D5-Evo Low-Voltage Installation Manual



Company Profile



**In-house
R&D
development
team**



**Manufacture to
international
quality standard
ISO 9001:2008**

**100%
testing of
products**

**After-sales
multi-language
Technical Support
from 07h00 to 18h00
UTC+2
Monday to Friday**

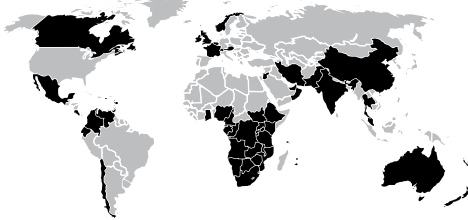

**Sales and technical support
to Africa, Europe, Asia,
the Americas, Australia
and the Pacific**

Centurion Systems (Pty) Ltd reserves the right to make changes to the products described in this manual without notice and without obligation of **Centurion Systems (Pty) Ltd** to notify any persons of any such revisions or changes. Additionally, **Centurion Systems (Pty) Ltd** makes no representations or warranties with respect to this manual. No part of this document may be copied, stored in a retrieval system or transmitted in any form or by any means electronic, mechanical, optical or photographic, without the express prior written consent of **Centurion Systems (Pty) Ltd**.



Contents

FAST TRACK	Mechanical Setup	page 5
	Electrical Setup	page 6
	Commissioning and Handover	page 6
<hr/>		
SAFETY FIRST	IMPORTANT SAFETY INSTRUCTIONS	page 7
	Declaration of conformity	page 9
1.	Icons Used in this Manual	page 10
2.	General Description	page 11
3.	Specifications	page 13
3.1.	Physical Dimensions	page 13
3.2.	Technical Specifications	page 14
3.3.	Fuse Protection	page 15
4.	Product Identification	page 16
5.	Required Tools and Equipment	page 17
6.	Preparation of Site	page 18
7.	Cabling Requirements	page 22
8.	Lubrication	page 23
9.	Operator Installation	page 24
9.1.	Foundation plate installation	page 26
9.2.	Route Cables and Secure Foundation Plate	page 27
9.3.	Mount The Gearbox	page 28
9.4.	Mount The Rack	page 29
9.5.	Mount The Origin Marker	page 33
9.6.	Apply Warning Decal	page 35
10.	Electrical Setup	page 36
10.1.	Wiring Diagram for Closing Safety Beams/ Photocells	page 37
10.2.	Wiring Diagram for Opening Safety Beams/ Photocells	page 38
10.3.	Wiring Diagram for External Radio Receiver and Loop Detector	page 39

10.4.	Wiring Diagram for Other Inputs	page 40
10.5.	Wiring Diagram for Solar Panel	page 41
10.6.	Mains Supply, Battery, Charger And Pillar Light Connections	page 42
10.7.	Wiring Diagram for Pillar Light to D5-Evo Low-Voltage	page 43
10.8.	Earthing for Effective Lightning Protection	page 44
11.	Commissioning the System	page 45
11.1.	Setting the Gate Limits	page 45
12.	How to Set up Additional Features on the D5-Evo or D5-Evo Low-Voltage controller	page 46
13.	Menu Navigation Map	page 47
14.	Controller Features	page 51
15.	Factory Defaults Schedule	page 64
16.	Description of Terminal Functions	page 66
17.	Diagnostics	page 69
17.1.	Diagnostic LEDs	page 69
17.2.	Gate Status LED Indication	page 69
17.3.	LCD Display	page 70
17.4.	Buzzer Feedback	page 71
18.	Fault-finders Guide	page 73
18.1.	Procedure A - Low Battery Voltage Condition	page 76
18.2.	Procedure B - False collision detection	page 77
19.	Manual Operation	page 78
20.	Installation Handover	page 79

FAST TRACK Mechanical Setup

These abbreviated instructions are for the experienced installer who needs a checklist to get a standard installation up and running in the minimum of time.

Detailed installation features and functions are referred to later in this manual.

STEP 1

Heed necessary site considerations

STEP 2

Check cabling requirements

STEP 3

Gather required tools and equipment

STEP 4

Secure foundation plate

STEP 5

Add oil to gearbox

STEP 6

Mount gearbox

STEP 7

Mount rack

STEP 8

Mount origin marker

STEP 9

Apply warning decals

Electrical Setup

STEP 10

Connect all wiring

Commissioning & Handover

STEP 11

Set gate end-of-travel limits

STEP 12

Set additional features via the menus, if required

STEP 13

Carry out professional Handover to client

IMPORTANT SAFETY INSTRUCTIONS

ATTENTION

To ensure the safety of people and possessions, it is important that you read all the following instructions.

Incorrect installation or incorrect use of the product could cause serious harm to people.



The installer, being either professional or DIY, is the last person on the site who can ensure that the operator is safely installed, and that the whole system can be operated safely.

Warnings for the Installer

CAREFULLY READ AND FOLLOW ALL INSTRUCTIONS before beginning to install the product.

- All installation, repair, and service work to this product must be carried out by a suitably qualified person
- This appliance is not intended for use by persons (including children) with reduced physical, sensory or mental capabilities, or lack of experience and knowledge, unless they have been given supervision or instruction concerning use of the appliance by a person responsible for their safety
- Do not activate your gate unless you can see it and can determine that its area of travel is clear of people, pets, or other obstructions
- **NO ONE MAY CROSS THE PATH OF A MOVING GATE;** always keep people and objects away from the gate and its area of travel
- **NEVER LET CHILDREN OPERATE OR PLAY WITH THE GATE CONTROLS**
- Secure all easily-accessed gate opener controls in order to prevent unauthorised use of the gate
- Do not in any way modify the components of the automated system
- Do not install the equipment in an explosive atmosphere: the presence of flammable gasses or fumes is a serious danger to safety
- Before attempting any work on the system, cut electrical power to the operator and disconnect the batteries
- The Mains power supply of the automated system must be fitted with an all-pole switch with contact opening distance of 3mm or greater; use of a 5A hydraulic breaker with all-pole circuit break is recommended
- Make sure that an earth leakage circuit breaker with a threshold of 30mA is fitted upstream of the system

- Never short-circuit the battery and do not try to recharge the batteries with power supply units other than that supplied with the product, or manufactured by Centurion Systems (Pty) Ltd
- Make sure that the earthing system is correctly constructed, and that all metal parts of the system are suitably earthed
- Safety devices must be fitted to the installation to guard against mechanical movement risks such as crushing, dragging and shearing
- It is recommended that at least one warning indicator light be fitted to every system
- Always fit the warning signs visibly to the inside and outside of the gate
- The installer must explain and demonstrate the manual operation of the gate in case of an emergency, and must hand the User Guide/Warnings over to the user
- The installer must explain these safety instructions to all persons authorised to use this gate, and be sure that they understand the hazards associated with automated gates
- Do not leave packing materials (plastic, polystyrene, etc.) within reach of children as such materials are potential sources of danger
- Dispose of all waste products like packing materials, worn-out batteries etc, according to local regulations
- Always check the obstruction detection system, and safety devices for correct operation
- Neither Centurion Systems (Pty) Ltd, nor its subsidiaries, accept any liability caused by improper use of the product, or for use other than that for which the automated system was intended
- This product was designed and built strictly for the use indicated in this documentation; any other use, not expressly indicated here, could compromise the service life/operation of the product and/or be a source of danger
- Everything not expressly specified in these instructions is not permitted



Declaration of Conformity

Manufacturer

Centurion Systems (Pty) Ltd.
Unit 13 Production Park
Intersection Newmarket Road & Epsom Avenue
North Riding
Gauteng
South Africa

Declares that the product

Product name: **D5-Evo and D5-Evo Low-Voltage**

Conforms with the following specifications

Safety: SANS 60335-1:2007
IEC 60335-1:2006

Emissions: CISPR 22 CLASS B: Radiated emissions – 150KHz TO 6GHz
CISPR 22 CLASS B: Conducted emissions – 150KHz TO 6GHz

Immunity: IEC 61000-4-2 – Electrostatic discharge
IEC 61000-4-3 – Radiated immunity – 80MHz TO 1000MHz
IEC 61000-4-4 – Electrical fast transients/burst
IEC 61000-4-5 – Surges
IEC 61000-4-6 – Conducted immunity – 150KHz TO 80MHz

Standard to which conformity is declared

IEC 60335-1:2006	Safety
IEC 61000-6-3:2006	Emissions
IEC 61000-6-1:2005	Immunity

Signed at North Riding, South Africa on June 21, 2010



Ian Rozowsky
Research & Development Director.

1. Icons Used in this Manual



This icon indicates tips and other information that could be useful during the installation.



This icon denotes variations and other aspects that should be considered during installation.



This icon indicates warning, caution or attention! Please take special note of critical aspects that MUST be adhered to in order to prevent injury.

2. General Description

The **D5-Evo** or **D5-Evo Low-Voltage** is a domestic and light-industrial operator designed to open and close sliding gates weighing up to 500kg. A custom-designed gearbox moulded from robust engineering polymers, coupled to a powerful 12V DC motor, provides fast and reliable automation for entrances to homes and small housing estates.

The system operates off a 12V battery housed inside the operator using a switch mode charger to maintain the battery in a fully charged state. The battery provides critical power failure protection. A solar supply can be used as an alternative energy source to charge the battery.

Gate travel limits are managed by an opto-electronic system, comprising a gate-mounted origin magnet and an internal rotary encoder. This system yields precise and repeatable control over gate position.

Homeowners who do not have mains power at their gates can still enjoy all the amazing features and functionality of this flagship product - without having to foot gigantic installation bills - thanks to the **D5-Evo Low-Voltage** model.

Instead of a conventional charger which relies upon a high-voltage AC input, the **D5-Evo Low-Voltage** comes with a rectifier/regulator which requires a low-voltage input of 15V to 19V AC; this can be easily supplied using a plug-in step-down transformer (typically installed in dwelling) and saves the user having to route expensive high-voltage cables and obtaining a certificate of compliance.

Advanced features of the D5-Evo or D5-Evo Low-Voltage logic controller include:

- Interactive graphical user interface via a backlit LCD display
- Automated setup of gate endpoints (limits)
- Fail-safe collision detection and auto reverse (adjustable sensitivity)
- Smooth, adjustable start/stop (ramp up/ramp down)
- Multiple operational modes
- Selectable, adjustable Autoclosing
- Pedestrian (partial) opening
- Positive Close Mode
- Independent safety inputs for opening and closing beams
- Automatic beam test for both open and closing beams
- Advanced beam alarm functions
- Advanced lightning/surge protection
- Timed courtesy light output
- Multiple pre-flashing modes
- Independently adjustable motor speed in both opening and closing directions
- Onboard NOVA Code-hopping radio receiver with full channel mapping capability (limited to 500 buttons)
- Onboard ChronoGuard timer (patent pending) for auto-activation of various physical inputs and outputs and time-barring of the same inputs and output including remote controls

Lightning Protection

The electronic controller utilises the same proven surge protection philosophy that is used in all our products. While this does not guarantee that the unit will not be damaged in the event of a lightning strike or power surge, it greatly reduces the likelihood of such damage occurring. The earth return for the surge protection is provided via the mains power supply earth and/or earth spike located next to the operator.



In order to ensure that the surge protection is effective, it is essential that the unit is properly earthed.

Theft Protection

While care has been taken in the design of the **D5-Evo or D5-Evo Low-Voltage** to prevent unauthorised removal (theft) of the unit, an optional steel theft-resistant cage is also available for added peace of mind.

3. Specifications

3.1. Physical Dimensions

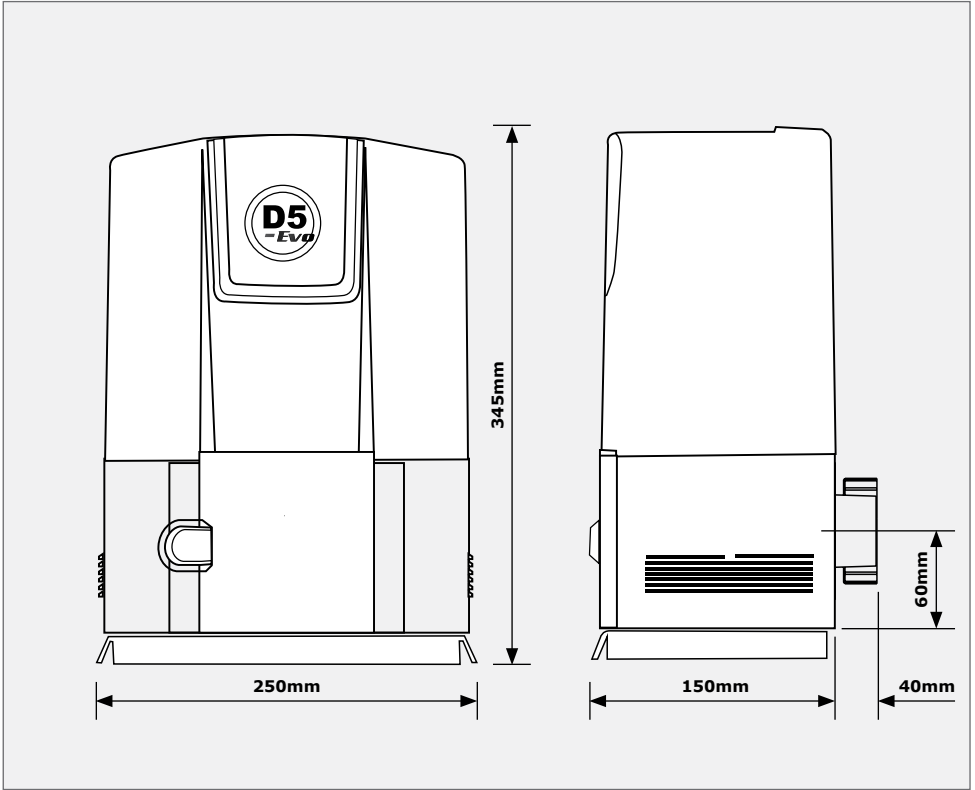

FIGURE 1. D5-EVO OVERALL DIMENSIONS

3.2. Technical Specifications - D5-Evo Operator

	D5-Evo	D5-Evo Low-Voltage
Input voltage	90V - 240V AC +/-10% @ 50Hz ¹	15V - 19V AC; 21V - 26V DC
Current consumption (mains)	170mA	NA
Battery charger amperage output (dependant on PSU input voltage)	90V AC input - 1A output	15V AC input - 400mA output
	240V AC input - 2.2A output	19V AC input - 1A output
Maximum numbers of operations per day	150	55
Duty cycle - mains present ^{2,3}	50%	20%
Motor voltage	12V DC	
Motor power supply	Battery-driven (standard capacity - 12V 7Ah) ⁴	
Current consumption (motor at rated load)	10A	
Motor push force - starting	30kgf	
Motor push force - rated	17kgf	
Gate mass - maximum	500kg	
Gate length - maximum	100m	
Gate speed (varies with load) ⁵	18 - 22m/min	
Manual Override	Lockable with key release	
Operations in standby with 7Ah battery		
Half day ⁶	44	
Full day ⁶	35	
Collision Sensing	Electronic	
Operating temperature range	-15°C to +50°C	
Onboard receiver type	Code-hopping multichannel receiver with selective add and delete	
Receiver code storage capacity	500 transmitter buttons	
Receiver frequency	433MHz	
Degree of protection	IP55	
Mass of unit packed (with standard kit, but excl. rack and battery)	10kg	
Packaging dimensions (with standard kit, but excl. rack and battery)	303mm wide x 231mm deep x 432mm high	

TABLE 1

1. Can operate off a solar supply, consult your local dealer for assistance
2. Based on 25°C ambient temperature and unit not in direct sunlight
3. Based on an motor push force of less than 50% of rated
4. Can increase battery capacity for longer standby times

5. Gate opening and closing speeds can be configured to run slower depending on the requirements of individual installations
6. Based on four metre gate, excluding infrared safety beams

3.3. Fuse Protections

The following protection fuses are provided on the system:

Item	Type	Rating
Main controller		
Motor circuit	Automotive fuse ATO (25 x 7mm)	30A
Light circuit	5 x 20mm	3A fast blow
Auxiliary supply	Resettable fuse	3A
Charger		
Mains input	5 x 20mm	3A fast blow

TABLE 2

4. Product Identification

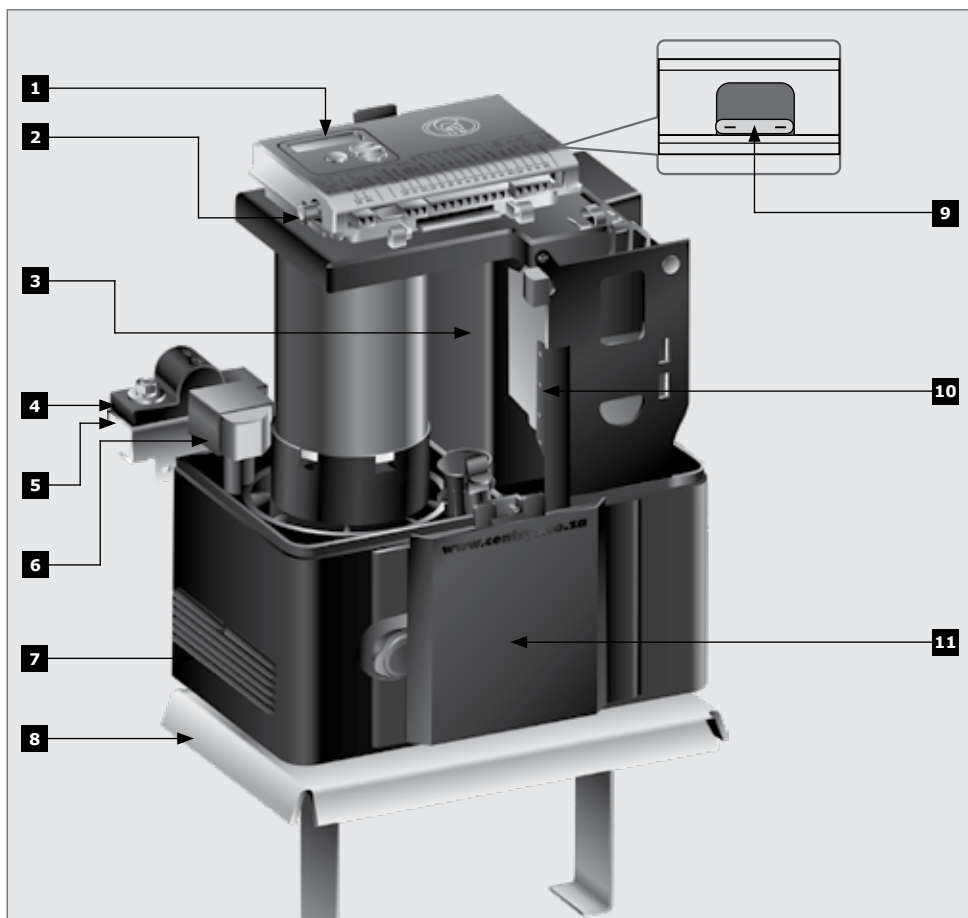

FIGURE 2. PRODUCT IDENTIFICATION

- | | |
|---|--|
| <ul style="list-style-type: none"> 1. D5-Evo or D5-Evo Low-Voltage controller 2. Courtesy light fuse (3A F/B) 3. 1 x 12V 7.2 Ah battery 4. Gate mounted origin marker 5. Origin marker bracket 6. Origin sensor | <ul style="list-style-type: none"> 7. Slide covers 8. Foundation plate 9. Motor fuse (30A ATO) 10. Switch Mode 2A charger ¹ 11. Manual release access door |
|---|--|
1. D5-Evo Low-Voltage comes with CP84XTE voltage regulator/rectifier instead of 2A switched-mode charger

5. Required Tools & Equipment



FIGURE 3

6. Preparation of Site

6.1. General Considerations for the Installation

Always recommend the fitment of additional safety equipment such as safety edges and safety beams, for additional protection against entrapment or other mechanical risks.

Check that no pipes or electrical cables are in the way of the intended installation

Check that enough space is available for the gate operator with the gate in the required open position.

Check for loose sandy soil if installing foundations, as the soil condition may require a larger foundation.

Never fit the operator on the outside of the gate, where the public has access to it

Install the gate operator only if:

- It will not pose a hazard to the public
- There is sufficient clearance to a roadway and/or public thoroughfares
- The installation will meet all municipal and/or local authority requirements once completed
- The gate mass, leaf width, allowable wind loading and application is within the operator specifications
- The gate is in good working order, meaning:
 - that it swings freely;
 - does not move on its own if left in any position;
 - it can be installed to have sufficient clearance between moving parts when opening and closing to reduce the risk of personal injury and entrapment;
- Pushbuttons or keyswitches, when required, can be positioned so that the gate is in line of sight of the operator

6.2. Endstops

Fit endstops capable of stopping the gate at rated speed. Refer to specifications at the beginning of this manual for the operating speed

Make $H > h$ to ensure gate will not jump over endstop

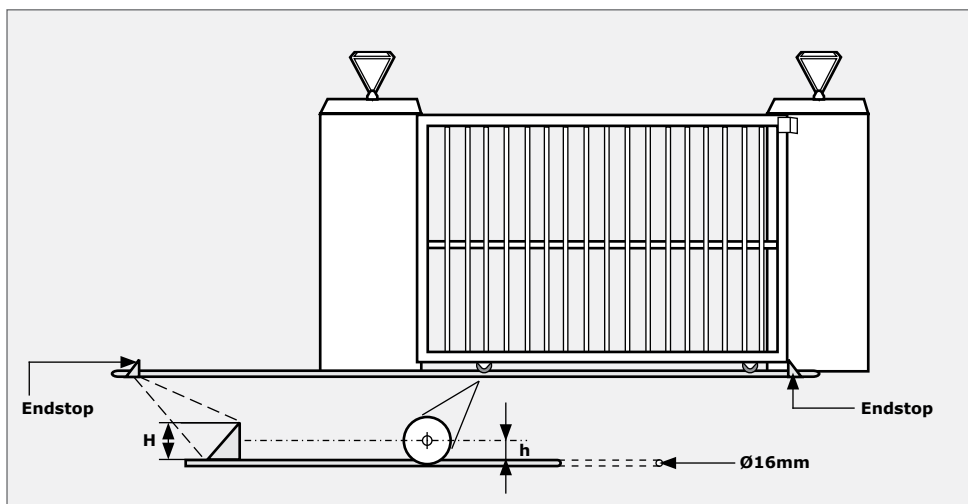

FIGURE 4. FITTING ENDSTOPS



Endstops are mandatory and must be fitted to prevent death or accidental injury should the gate overrun its limits.

6.3. Guide-rollers and anti-lift brackets

Guide-rollers must ensure that the gate is held vertically.

For improved safety, fit additional support posts to prevent gate from falling over if guide rollers fail.

To prevent unauthorised access fit anti-lift brackets as shown

The gap between the anti-lift bracket and the gate must be less than 5mm.



Ensure that the gate cannot be lifted off the motor pinion with the anti-lift bracket fitted.

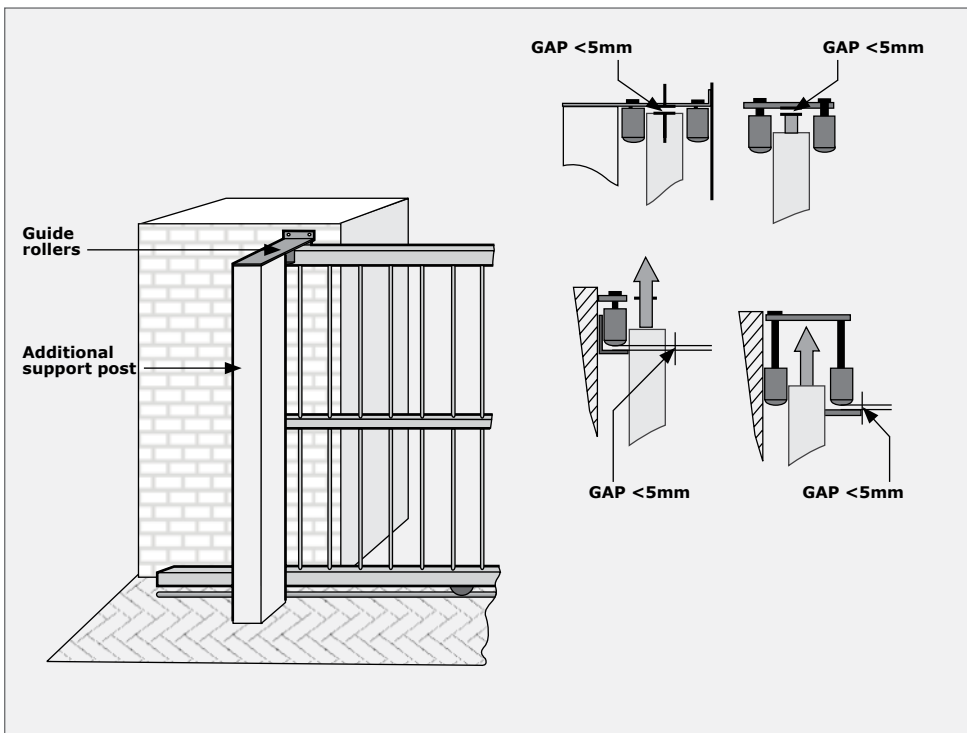

FIGURE 5. FITTING GUIDE ROLLERS

6.4. Starting and running forces

Test the starting force of the gate as per the diagram. Use a pull scale to determine the maximum amount of pull force required to get the gate moving.

Determine the running force of the gate by continuing to pull on the scale with just sufficient force to keep it running and read off the maximum value in kgf shown on the scale.

Where possible determine the gate mass.

Our warranty will be void if the pull force and/ or gate mass, exceed the operator specification as below:

- Starting force - 30kgf
- Running (rated) force - 20kgf
- Maximum gate mass - 500kg

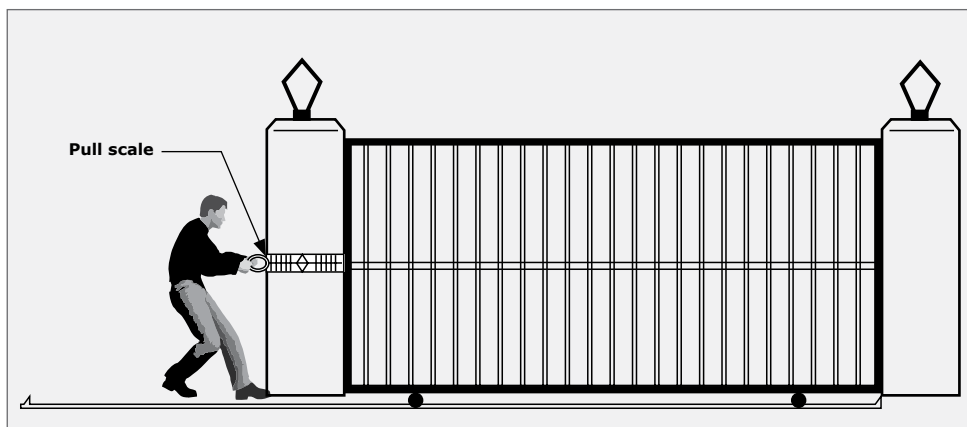

FIGURE 6. STARTING AND RUNNING FORCES

7. Cabling Requirements

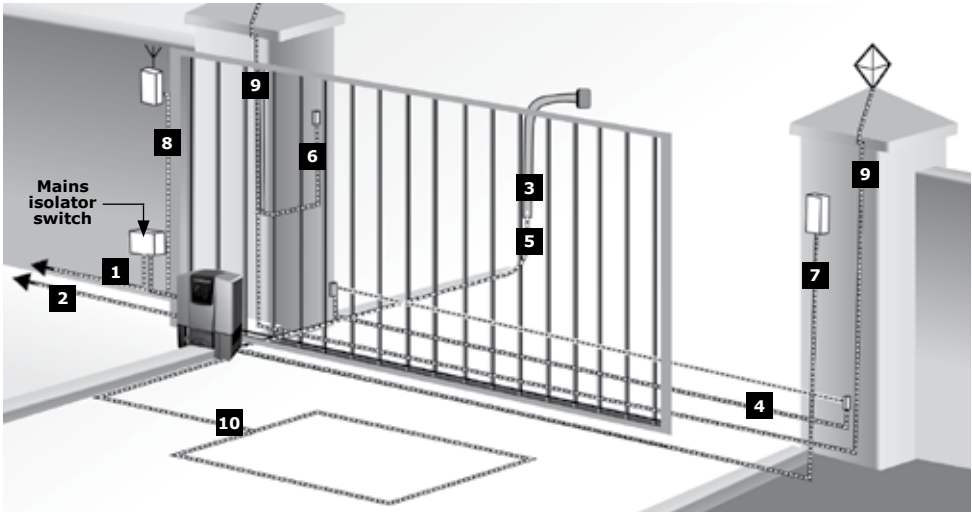

FIGURE 7. CABLING REQUIREMENTS

Legend

1. D5-Evo: 90V - 240V AC mains cable via double mains isolator switch (3 core LNE 1.5mm² SWA) or D5-Evo Low-Voltage: 15-19V AC / 21 - 26V DC cable via transformer in dwelling)^{1 2}
2. Optional intercom cable from motor to dwelling (n1 + 6 core³ 0.5mm² multi-stranded)
3. Optional intercom cable from motor to entry panel (n2 0.5mm² multi-stranded)
4. Optional but recommended infrared safety beams (3 core 0.5mm² multi-stranded)
5. Optional access control device (3 core 0.5mm² multi-stranded)
6. a. Optional pedestrian keyswitch (2 core 0.5mm² multi-stranded) OR
7. b. Optional keypad (3 core 0.5mm² multi-stranded)
8. Optional external radio receiver (3 core 0.5mm² multi-stranded)⁴
9. Optional pillar lights (3 core LNE SWA, size according to power requirements)⁵
10. Optional ground loop for free-exit (1core 0.5mm² multi-stranded – silicone coated) ⁵

n1 number of cores required by intercom

n2 number of cores required by intercom

1. Possibly increase cable thickness if pillar lights are installed

2. Type of cable must adhere to municipal bylaws but typically SWA (steel wire armoured) cable is recommended. The armouring provides excellent screening, which gives better protection against lightning – earth one end of the screening)

3. Allows for all features such as pedestrian opening, status LED, etc., to be operated from the intercom handset inside the dwelling. Number of cores and type of cable could vary depending on brand of access control system being used

4. For optimum range, an external receiver can be mounted on the wall

5. Consult manufacturer of loop detector for specific details

8. Lubrication



Do not attempt to run the operator without first filling the gearbox with lubricant.

- The internal gearset of the D5-Evo is lubricated by means of an oil bath
- In order to prevent possible leakage during shipping, the unit is shipped with no oil inside the gearbox. A bottle containing 80ml of a special synthetic oil is included with the product, and this must be introduced before operating the product. (Product code: OIL80ML0X0/H)



It is more convenient to introduce oil before bolting the unit down, as shown in Figure 6.

The D5-Evo does not require routine oil changes. However in the event of the unit losing oil due to stripping down or mechanical damage, the correct replacement oil is Castrol SAF X0 75W-90 synthetic final drive lubricant.



If the gearbox is bolted down in the horizontal position during filling, the correct level is reached when the oil level is in the flat section of the dipstick.

Emptying the 80ml bottle of oil provided will give sufficient oil.

Oil filling procedure

- Lift the cover of the operator
- Remove the battery so that you can gain access to the coloured filler plug
- Remove the coloured oil filler plug by levering it out with a screwdriver
- Empty the contents of the oil bottle into the gearbox (80ml)
- Refit the coloured oil filler cap

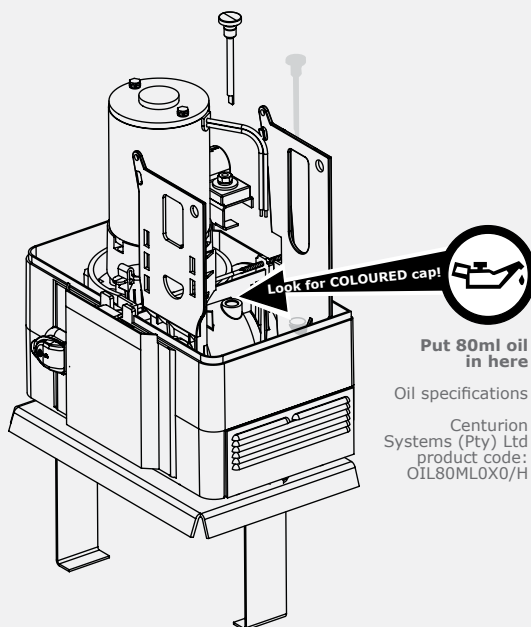

FIGURE 8. OPERATOR LUBRICATION

9. Operator Installation

Locate operator position

To ensure operator does not protrude into driveway, install base plate at least flush with the driveway entrance.

Determine a suitable position and vertical height for the operator by considering Figures 7, 8 and 9.

It is typical to mount the rack above the pinion as shown in Figures 7, 9A and 10A for each type of rack considered. However, in each case, Figures 8, 9B and 10B show the rack mounted underneath.

If there is space to mount the rack underneath without fouling the ground as the gate moves, the following are the pros and cons:



Pros

- The rack is more hidden from view
- It provides a very effective anti-lift bracket
- It ensures that as the gate beds in, the rack does not drop onto the pinion loading the operator unnecessarily

Cons



- Rack teeth face up vertically potentially collecting dirt
- Custom bracket
- With careful selection of the rack configuration, and operator vertical height, mounting of the rack could in some cases be greatly simplified
- If a theft-resistant cage is required, be sure to leave enough clearance from pillars, etc.
- If using nylon angle rack please ensure that the weight and pull force of the gate do not exceed the strength limit of the rack

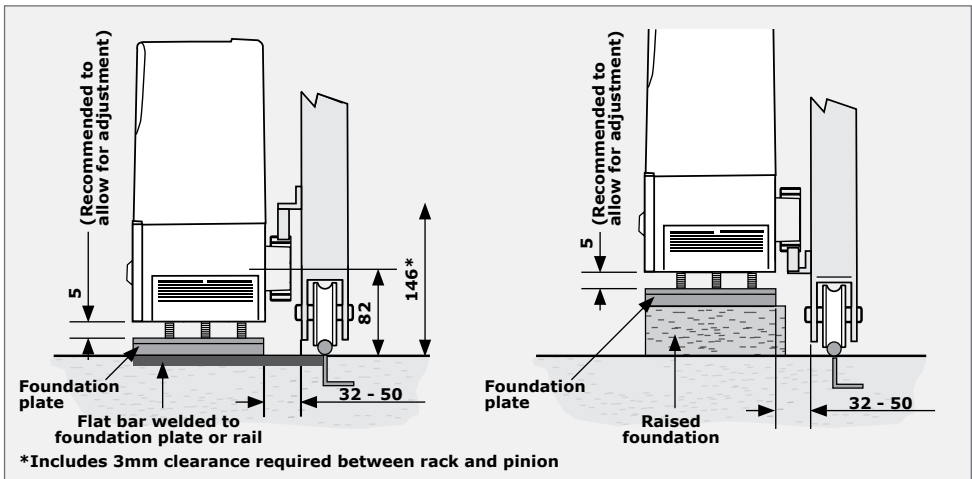

FIGURE 9A. STEEL RACK ABOVE PINION

FIGURE 9B. STEEL RACK BELOW PINION

RAZ rack

If using nylon angle rack please ensure that the weight and pull force of the gate do not exceed the strength limit of the rack.

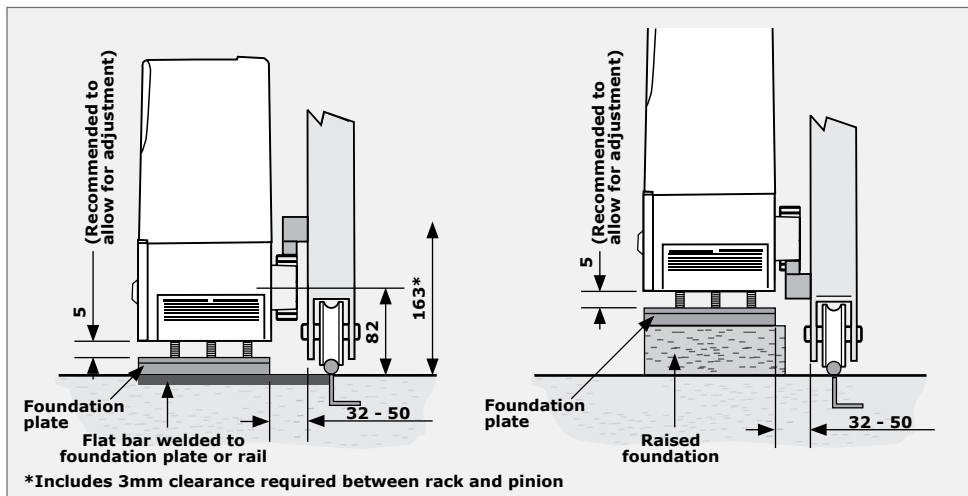

FIGURE 10A. RAZ RACK ABOVE PINION

FIGURE 10B. RAZ RACK BELOW PINION

Nylon angle rack

If using nylon angle rack please ensure that the weight and pull force of the gate do not exceed the strength limit of the rack.

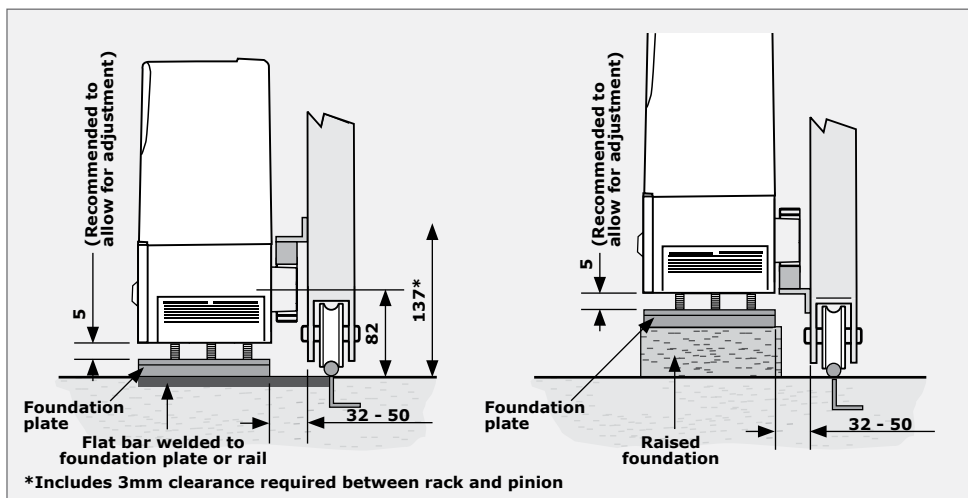

FIGURE 11A. NYLON RACK ABOVE PINION

FIGURE 11B. NYLON RACK BELOW PINION

9.1. Foundation plate installation

1. The foundation plate can either be set into a concrete foundation, as in Figure 12 or bolted down onto an existing concrete plinth as in Figure 14.

Option 1: Concrete foundation

2. Assemble foundation plate with anchor brackets as shown.



- **Ensure that the M10 gearbox mounting bolts are properly tightened**
- **Cable conduits must be installed before pouring the concrete (see next section)**

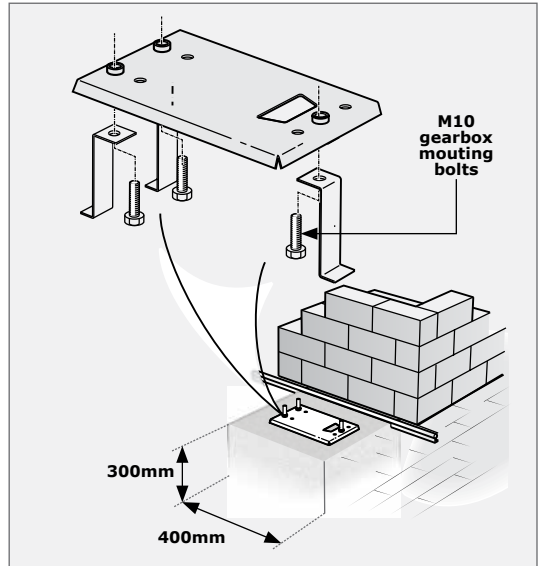

FIGURE 12

When using a concrete foundation, it is recommended that the foundation plate is welded to the rail/track of the gate using a short length of flat bar, as in Figure 13.



This makes it possible to complete the whole mechanical and electrical installation, without having to wait for the concrete to set. After completing the installation the concrete can be poured and the operator left in the manual mode until the concrete has set

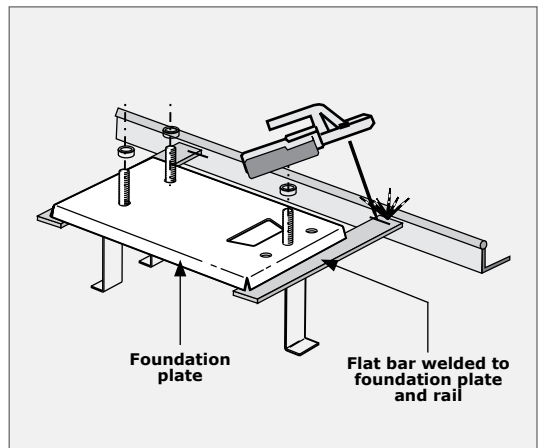

FIGURE 13

Option 2: Existing concrete plinth

3. If bolting onto an existing concrete plinth, place the foundation plate down in the correct position and use the plate as a template for marking the rawl bolt holes.
4. Assemble foundation plate without anchor brackets before bolting down onto plinth.



Ensure that the M10 gearbox mounting bolts are properly tightened

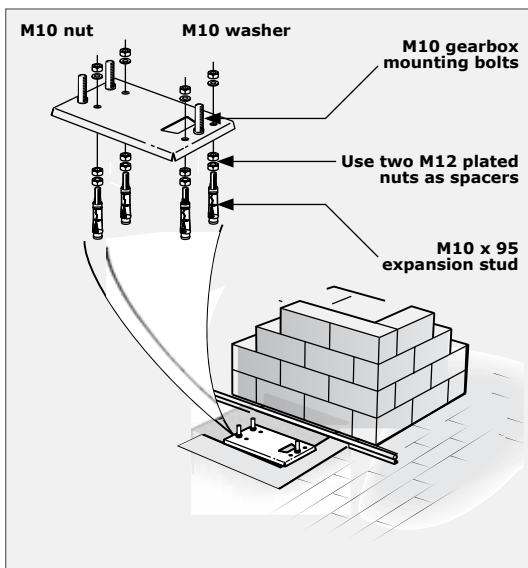

FIGURE 14

10.2. Route cables and secure foundation plate

1. Route cables as determined in Section 7, Cabling requirements.

2. Make sure that all cables and conduits protrude at least 400mm above the baseplate once installed as shown in Figure 14.



Make sure that the M10 bolts which secure the gearbox, are in place.

3. Securely concrete or bolt the foundation plate in position.

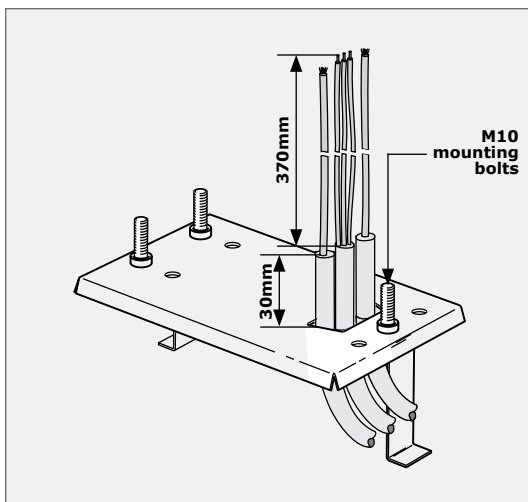

FIGURE 15

9.3. Mount the gearbox

1. Fit the M10 nuts and washers to the mounting bolts as shown in Figure 16
2. Adjust the nuts to be 7mm clear from the base to allow for later adjustment.



Remember to fit the washers onto each nut before installing the gearbox.

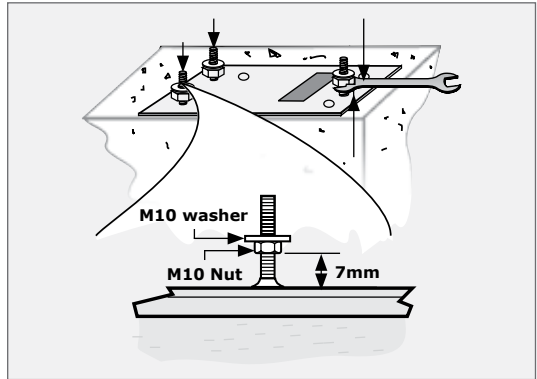

FIGURE 16

3. Remove the knock-outs for the cables from the gearbox.
4. Feed the cables through these holes while fitting the gearbox to the baseplate.
5. Note how the cables route up onto the control card.

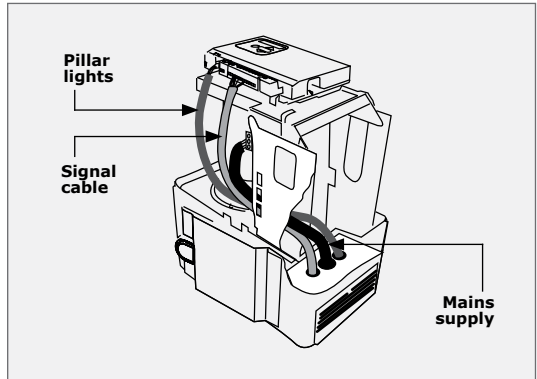

FIGURE 17

6. Check that the operator is level.
7. Secure the gearbox in place fitting a washer, spring washer and nut onto each gearbox mounting.
8. Seal the conduit and knock-out holes in the operator with silicone sealer to prevent ants from entering the operator through these cable entry points.

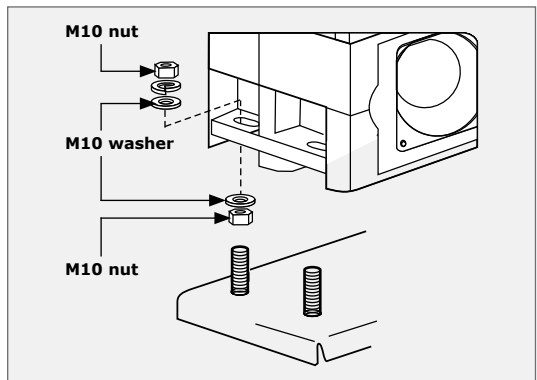

FIGURE 18

9.4. Mount the rack



The rack must be securely mounted to the side of the gate. It must be parallel with the gate rail, and there must be a 2 - 3mm gap between the teeth of the pinion.

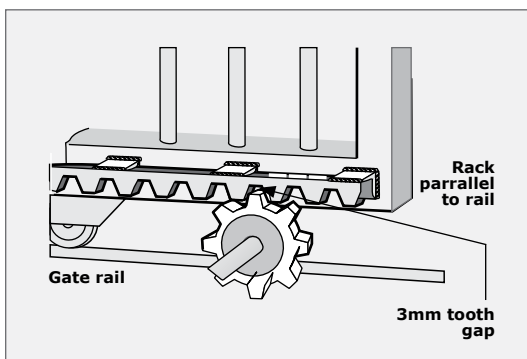

FIGURE 19



- Follow this procedure whether mounting steel, RAZ or nylon angle rack
- Refer to the sections that follow for specifics about the mounting of each type of rack

1. Before mounting the rack, raise the operator an additional 3mm.

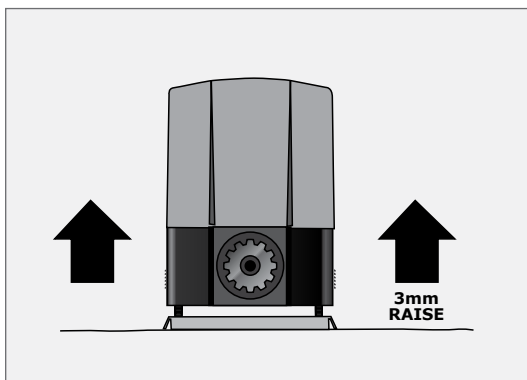

FIGURE 20

2. Put gearbox into manual mode. Refer to Section 19 for complete instructions.

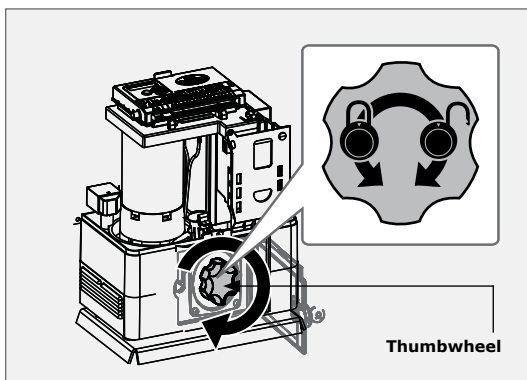

FIGURE 21

3. Start with the gate either fully open or closed.
4. Place the one end of the first section of rack on the pinion. Let it mesh fully.
5. Level the other end and fix that end to the side of the gate.

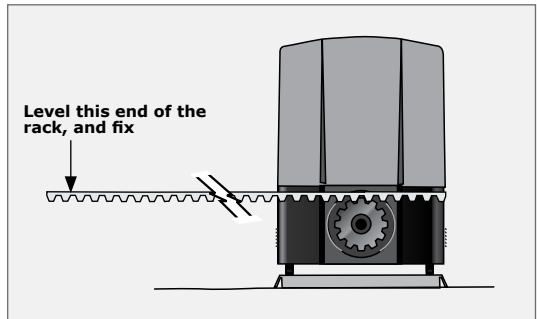

FIGURE 22



Refer to the sections that follow for instructions on how to fix the different types of rack.

6. Slide gate halfway along the first section.
7. Level the unsecured end, ensuring that the rack is resting on the pinion, not pressing down.
8. Before fully fixing each section of rack, slide gate backwards and forwards along the section, checking that the rack is only resting on the pinion, not pressing down.
9. Continue this way to fix all sections.

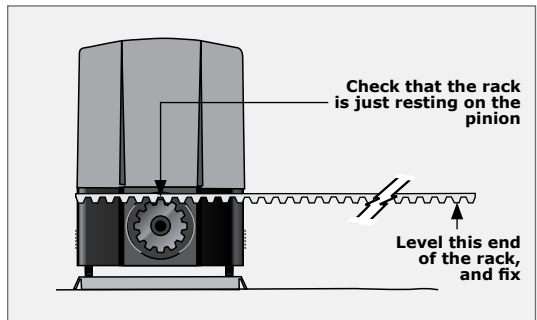

FIGURE 23



Refer to the sections that follow for instructions on how to join the different types of rack.

10. Finally lower the operator 3mm to achieve the required 3mm tooth clearance.
11. Ensure that operator mounting bolts are securely tightened.

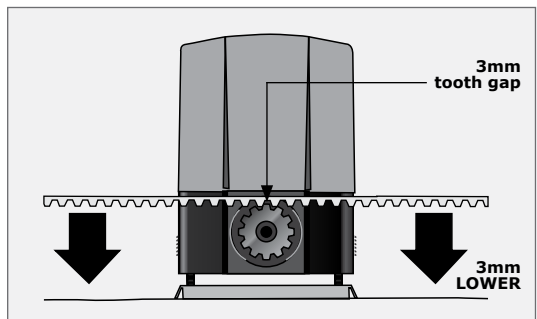

FIGURE 24

Steel rack

1. Fix rack using the steel angle brackets provided.
2. Brackets must be spaced no more than 300mm apart.

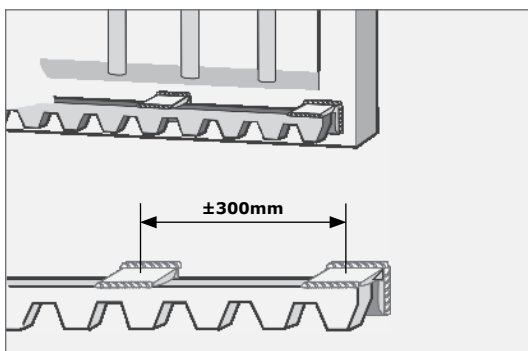

FIGURE 25

3. When joining different lengths of steel rack, a simple way of ensuring correct pitch spacing, is to clamp a small off-cut between the two pieces.

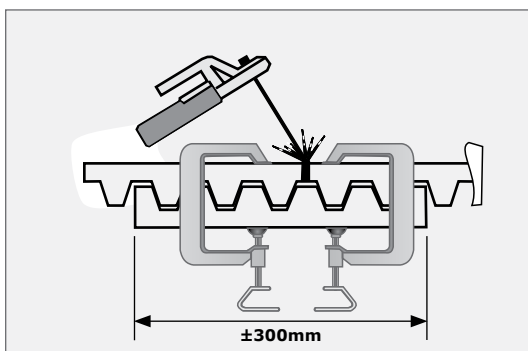

FIGURE 26

RAZ rack

4. Fix the RAZ rack to the side of the gate using the TEK screws provided. Use the vertical slots in order to allow adjustment.

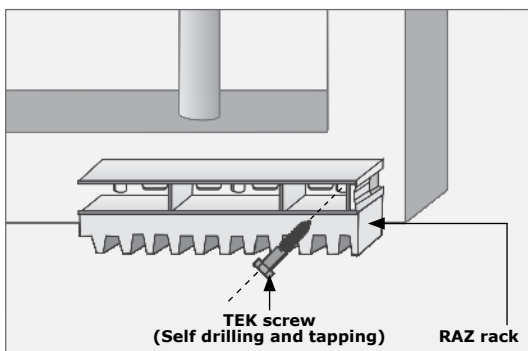

FIGURE 27

5. When fitting the RAZ rack it is easier to start on the right and work towards the left.
6. The RAZ rack simply clips together.

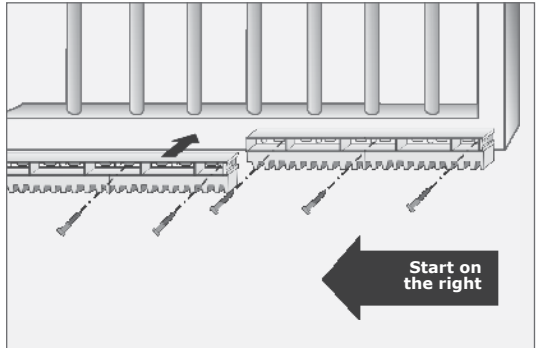

FIGURE 28A



Fit additional fixing screw through the horizontal slots to secure the rack to the gate directly above the pinion when the gate is in the closed, pedestrian and open positions.

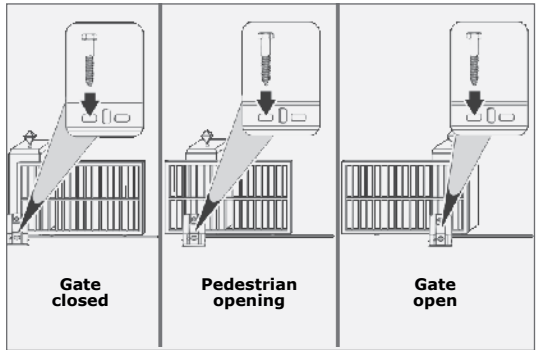

FIGURE 28B

Nylon angle rack

1. Fix rack to the side of the gate using the TEK screws.
2. Ensure that all the mounting holes provided in the angle section are used.

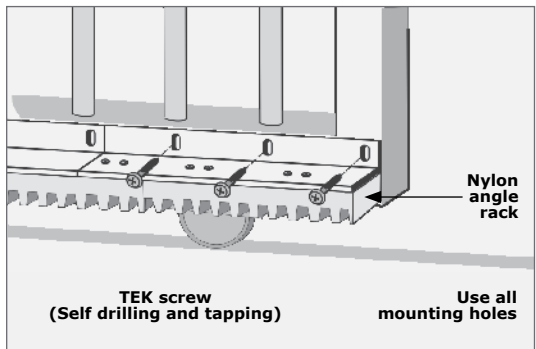

FIGURE 29

- When joining two lengths together, simply butt each section firmly together to ensure the correct pitch.

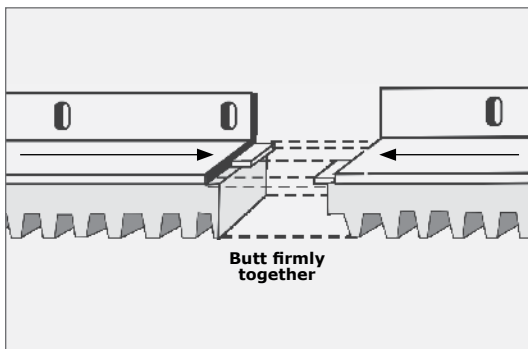

FIGURE 30

9.5. Mount the origin marker

- Close the gate completely.

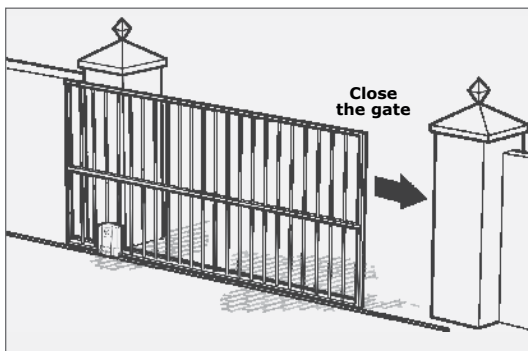

FIGURE 31

- Mount the origin marker to the rack a minimum of 500mm from the origin sensor. Refer to Figure 31, isometric view A or plan view B.

It is possible to make the distance between the marker and the sensor much greater than 500mm. However, if using the pedestrian opening facility, although the position of the marker will not affect the width of the pedestrian opening, it is preferable to have the marker mounted inside of the pedestrian opening point.

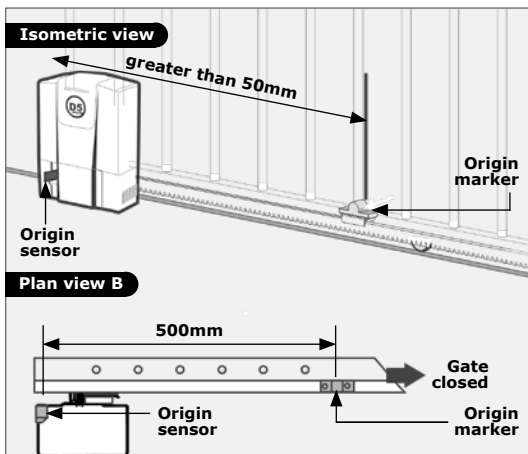

FIGURE 32

3. For steel rack mount the origin marker onto the rack using the bracket provided.
4. Weld the bracket to the rack.
5. Bolt the origin marker onto the bracket using the fasteners provided.

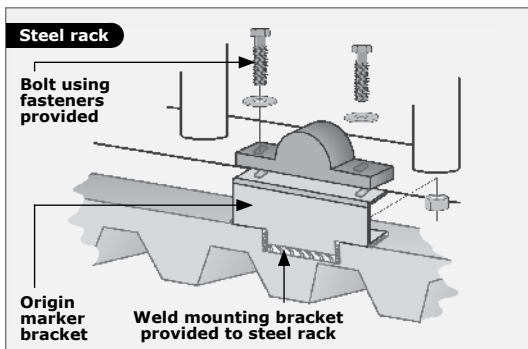

FIGURE 33

6. With the RAZ rack the origin marker mounts directly on top of the rack without a bracket.
7. Drill mounting holes directly into the rack and bolt into position.
8. File away the front lip of the rack if you need to move the origin marker closer to the operator as the gate slides past.

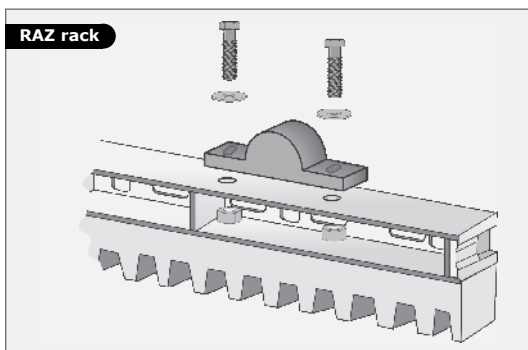

FIGURE 34

9. With nylon angle rack, it is necessary to use the bracket provided.
10. It is preferable to use self-tapping fasteners to secure the bracket into the side of the nylon angle rack as shown.
11. Make a small tack weld to secure the back of the bracket onto the angle iron section of the rack.
12. Bolt the origin marker onto the bracket using the fasteners provided.

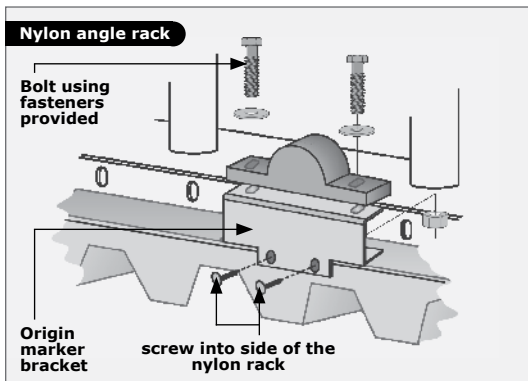

FIGURE 35

- Note the orientation of the origin marker.

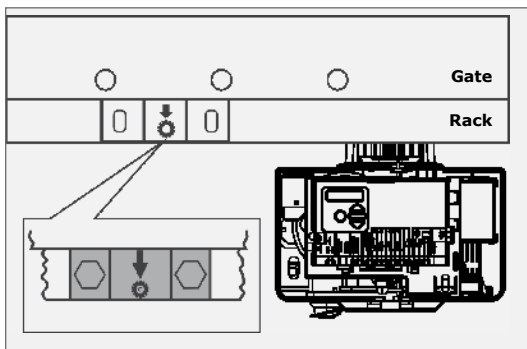

FIGURE 36

- Manually slide the gate open until the origin marker is in line with the origin sensor.
- Ensure distance between face of marker and front face of sensor is between 13 and 20mm.
- Adjust distance by sliding the slotted mounting holes until the specified distance is achieved.

! For best results, keep gap between marker and sensor as small as possible.

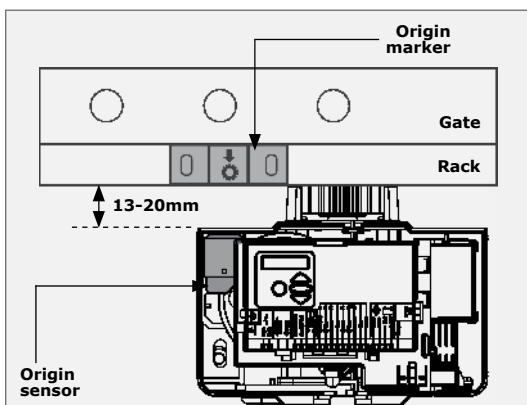

FIGURE 37

Apply warning decal

Apply the supplied warning decals to the gate as indicated on the reverse side of the decal.



10. Electrical Setup

1. Always check that the circuit breaker in the electrical panel is in the OFF position, and that all high-voltage circuits (more than 42.4V) are completely isolated from the mains supply before doing any work.
2. Ensure that all low-voltage systems (less than 42.4V) are suitably protected from damage, by disconnecting all sources of power such as chargers and batteries before doing any work.
3. All electrical work must be carried out according to the requirements of all applicable local electrical codes. (It is recommended that a licensed electrical contractor perform such work.)



Connect all Wiring

1. Connect all cables as required to the control card and battery charger, according to the wiring diagrams as shown in Section 10 that follows.

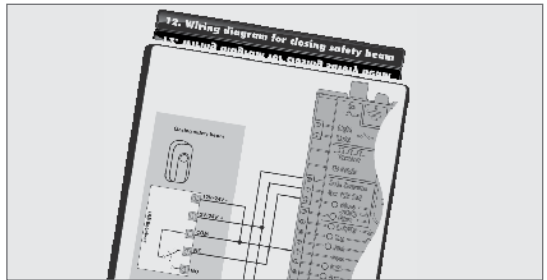

FIGURE 38

2. Ensure that both the controller and the charger are effectively earthed for improved lightning protection. Refer to Section 10.8.

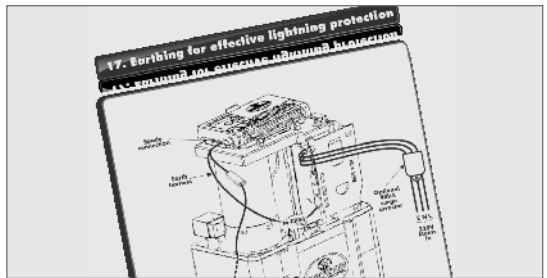

FIGURE 39

3. Check that the charger and battery are connected to the controller.



Ensure that the battery polarity is correct.

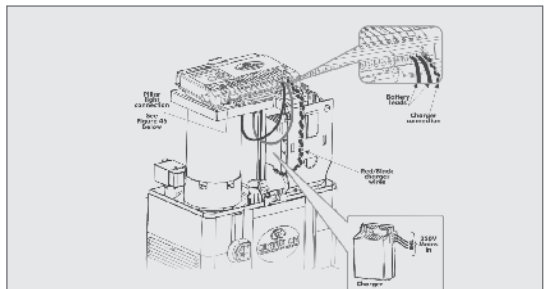

FIGURE 40

10.1. Wired Closing Safety Beams

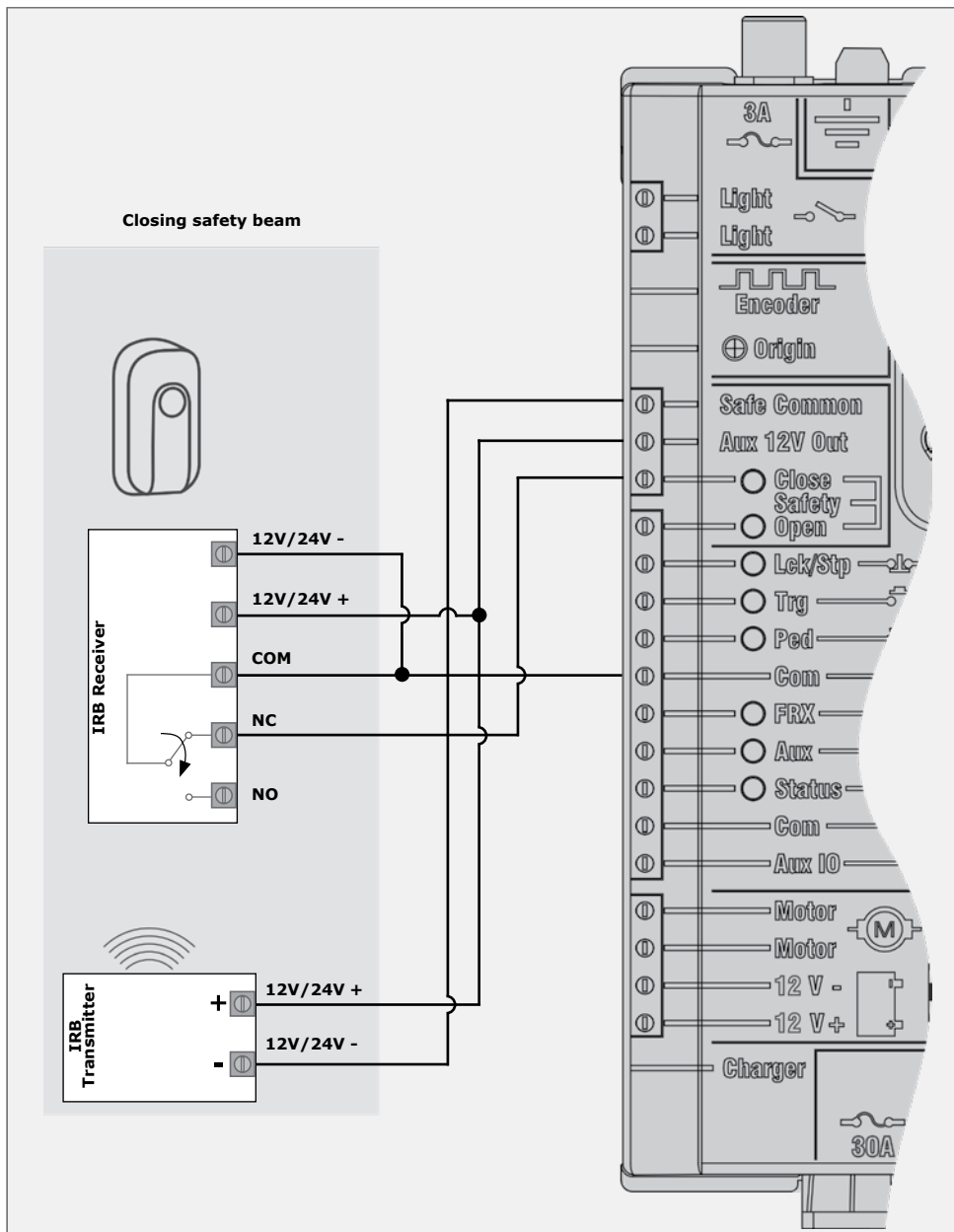

FIGURE 41. WIRED CLOSING SAFETY BEAMS

10.2. Wired Opening Safety Beams

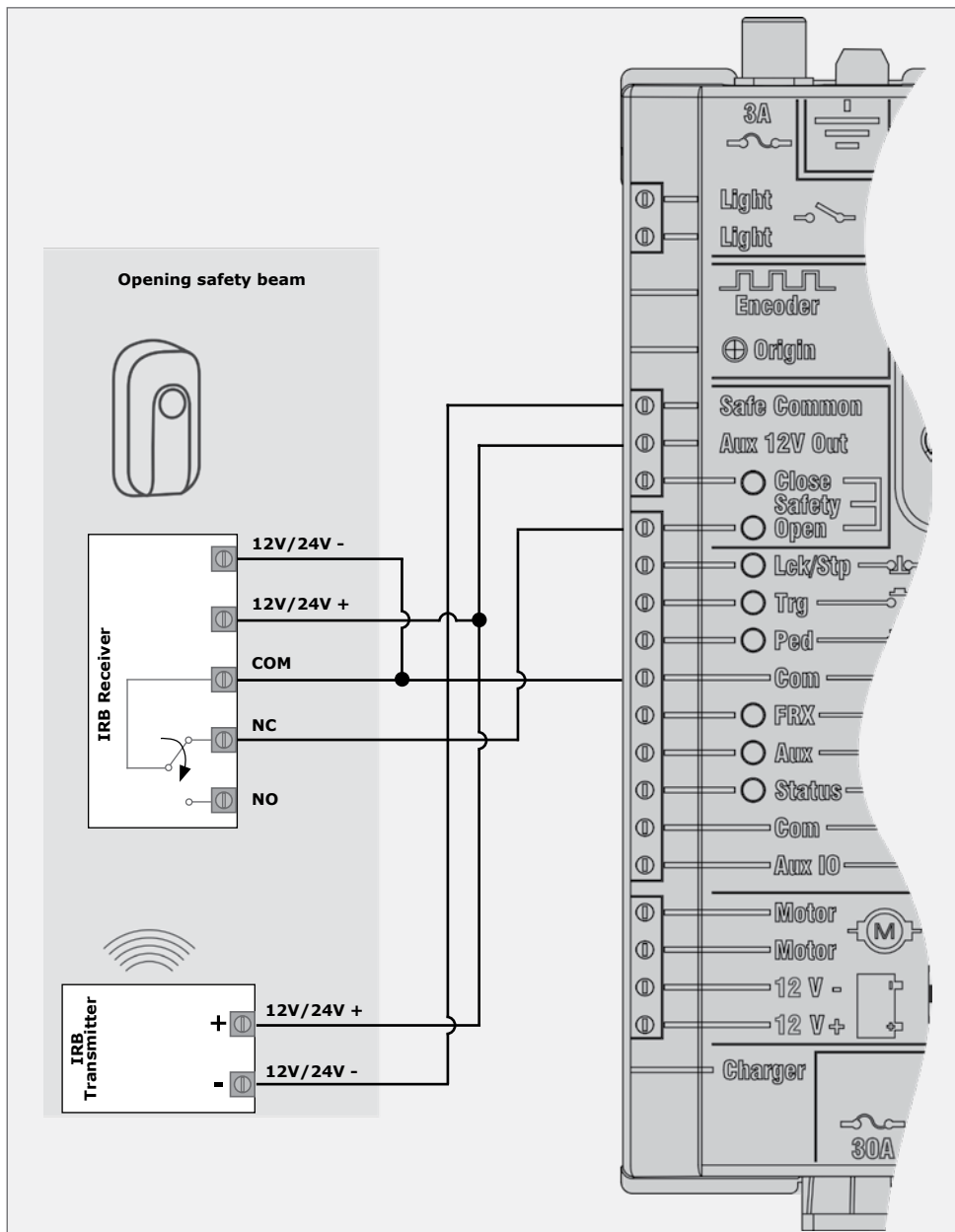

FIGURE 42. WIRED OPENING SAFETY BEAMS

10.3. External Radio Receiver & Loop Detector

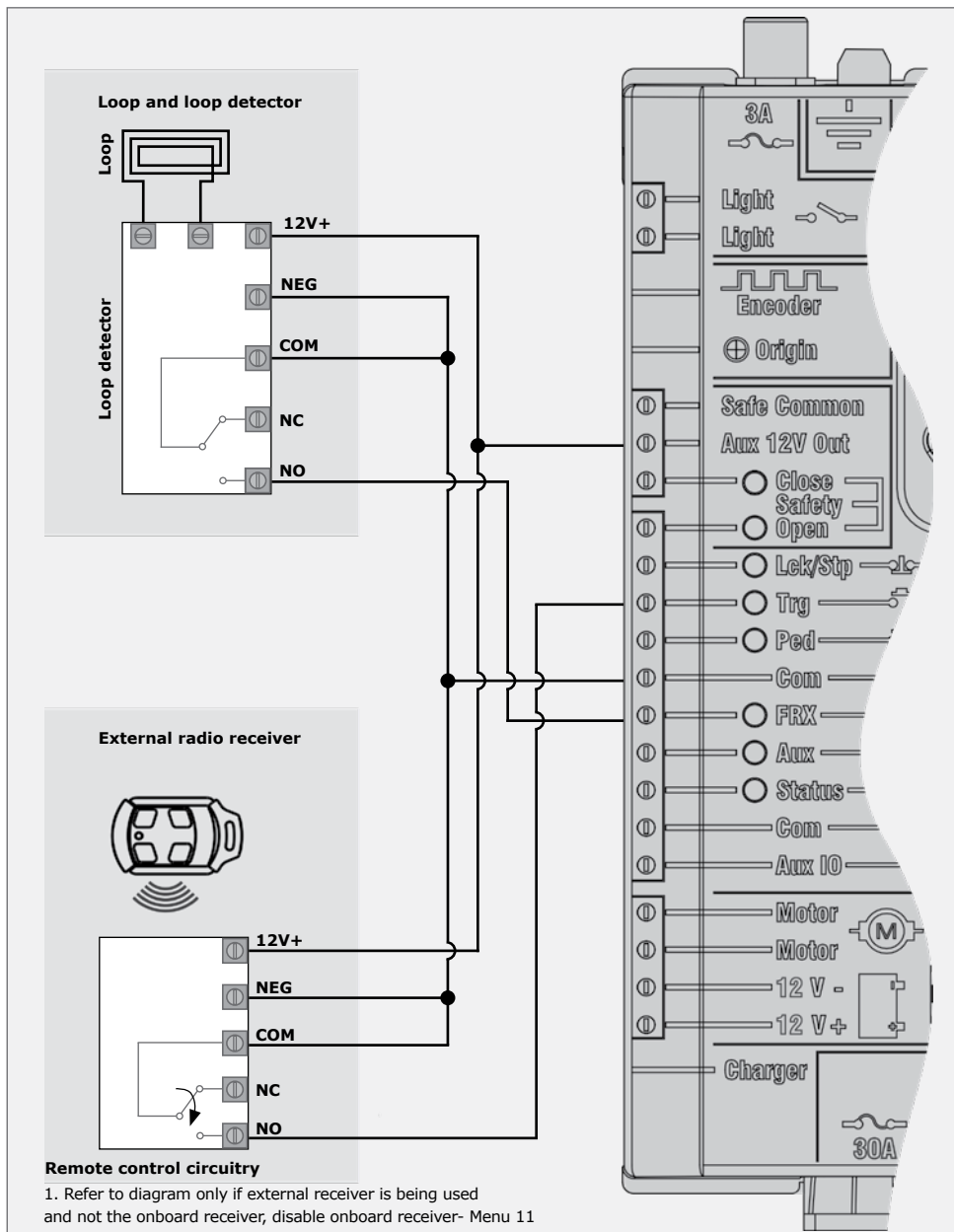

FIGURE 43. EXTERNAL RADIO RECEIVER & LOOP DETECTOR

10.4. Wiring Other Inputs

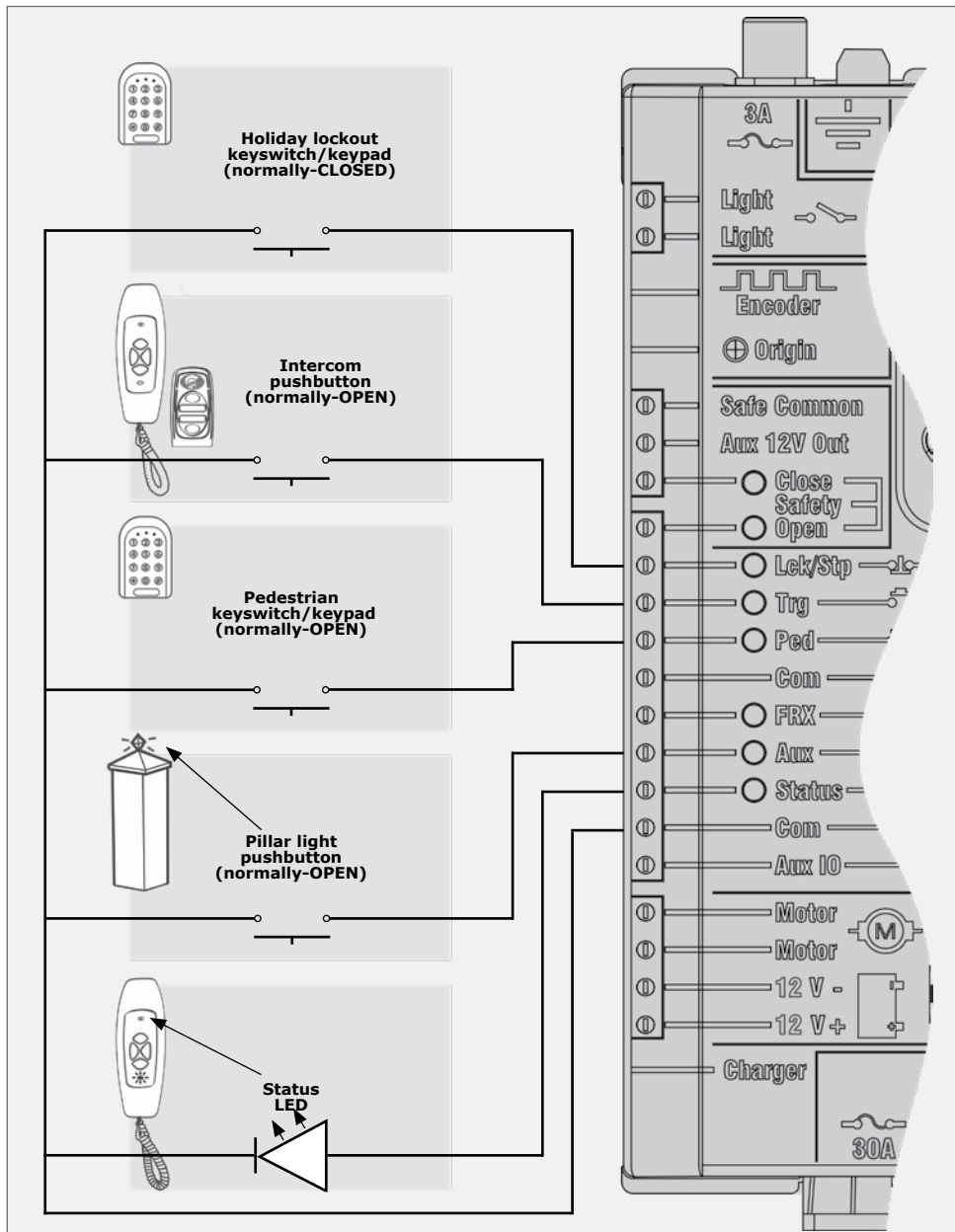

FIGURE 44. OTHER INPUTS

10.5. Wiring Diagram for Solar Panel

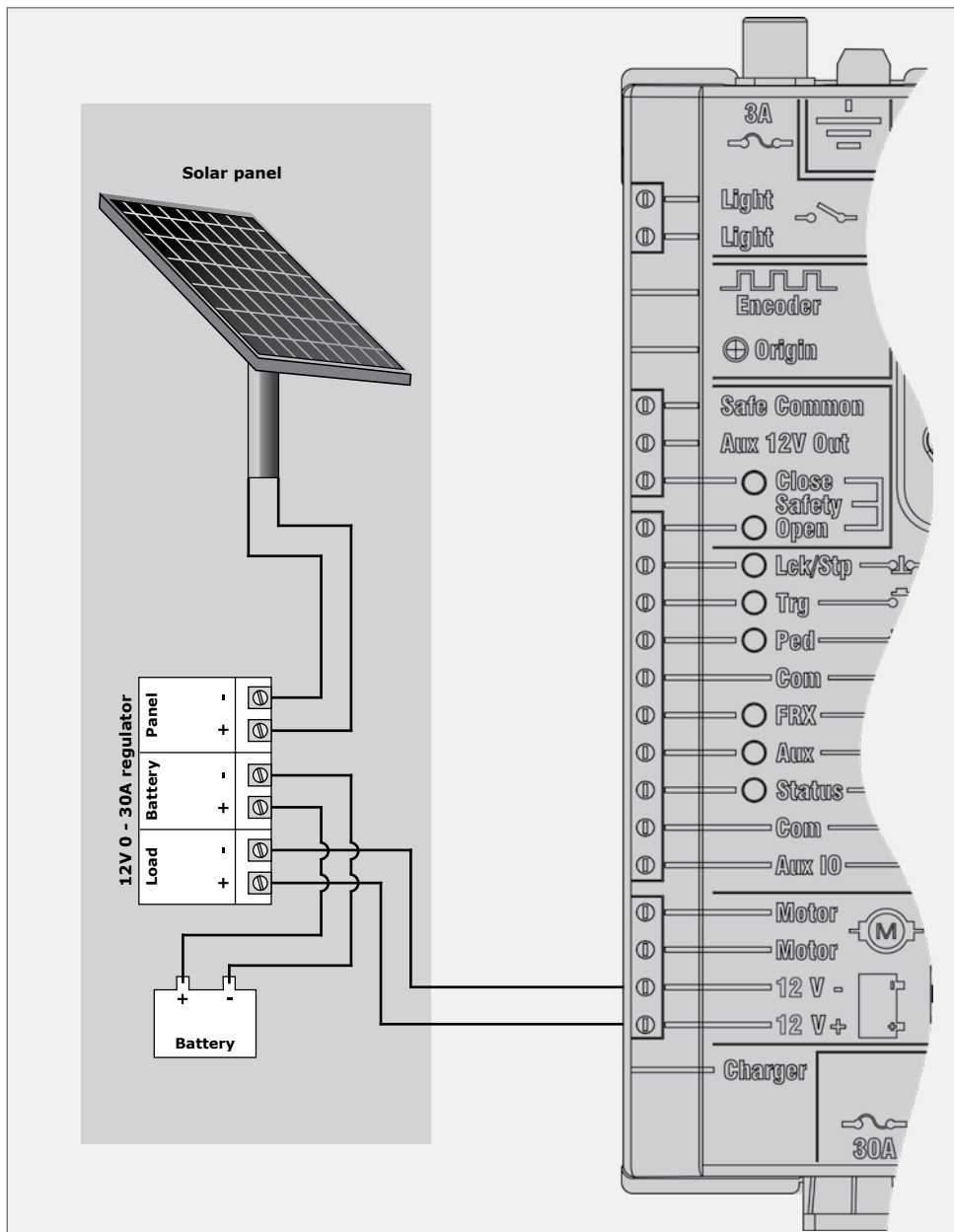

FIGURE 45. SOLAR WIRING

10.6. Main Supply, Battery Charger & Pillar Light

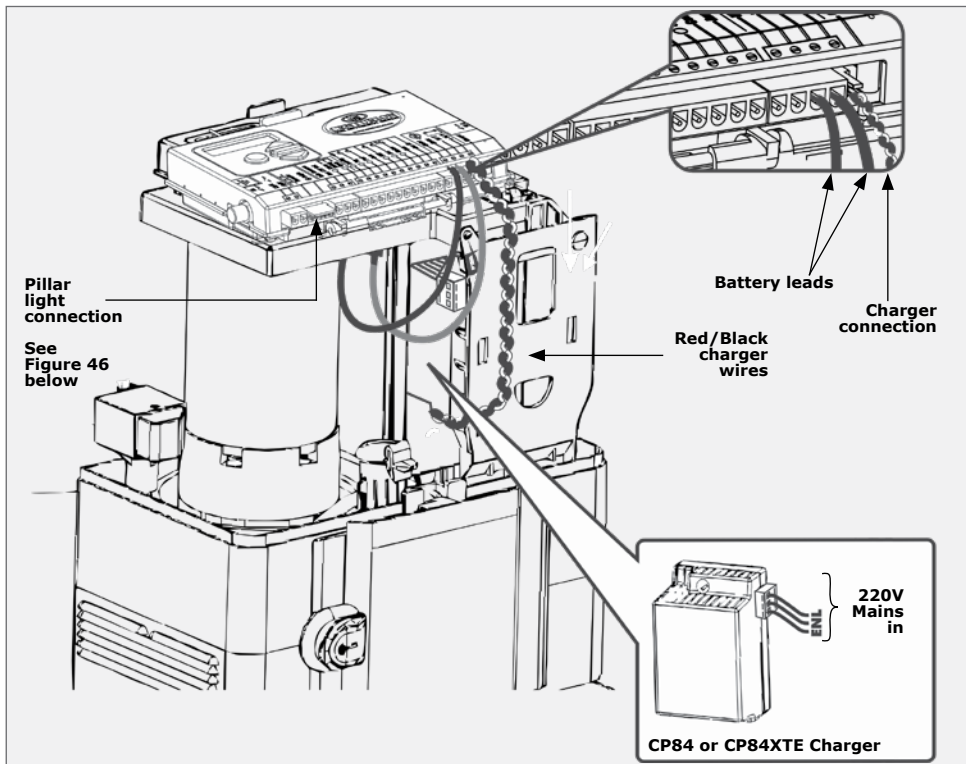

FIGURE 46. MAIN SUPPLY, BATTERY CHARGER & PILLAR LIGHT CONNECTIONS

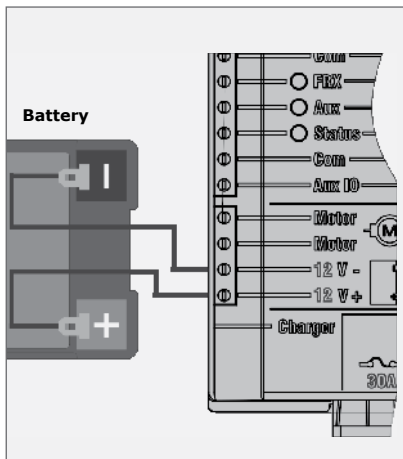

FIGURE 47

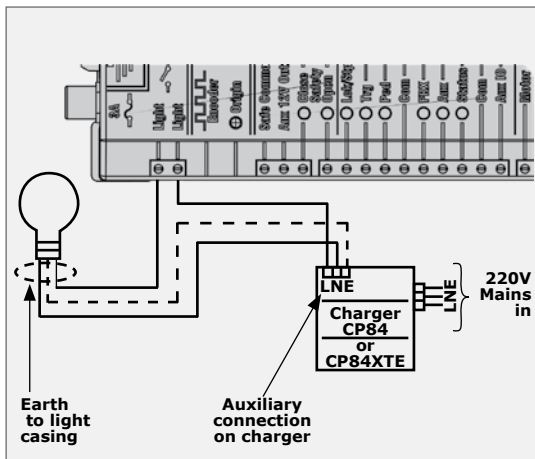

FIGURE 48

10.7. Wiring Diagram for Pillar Light to D5-Evo Low-Voltage

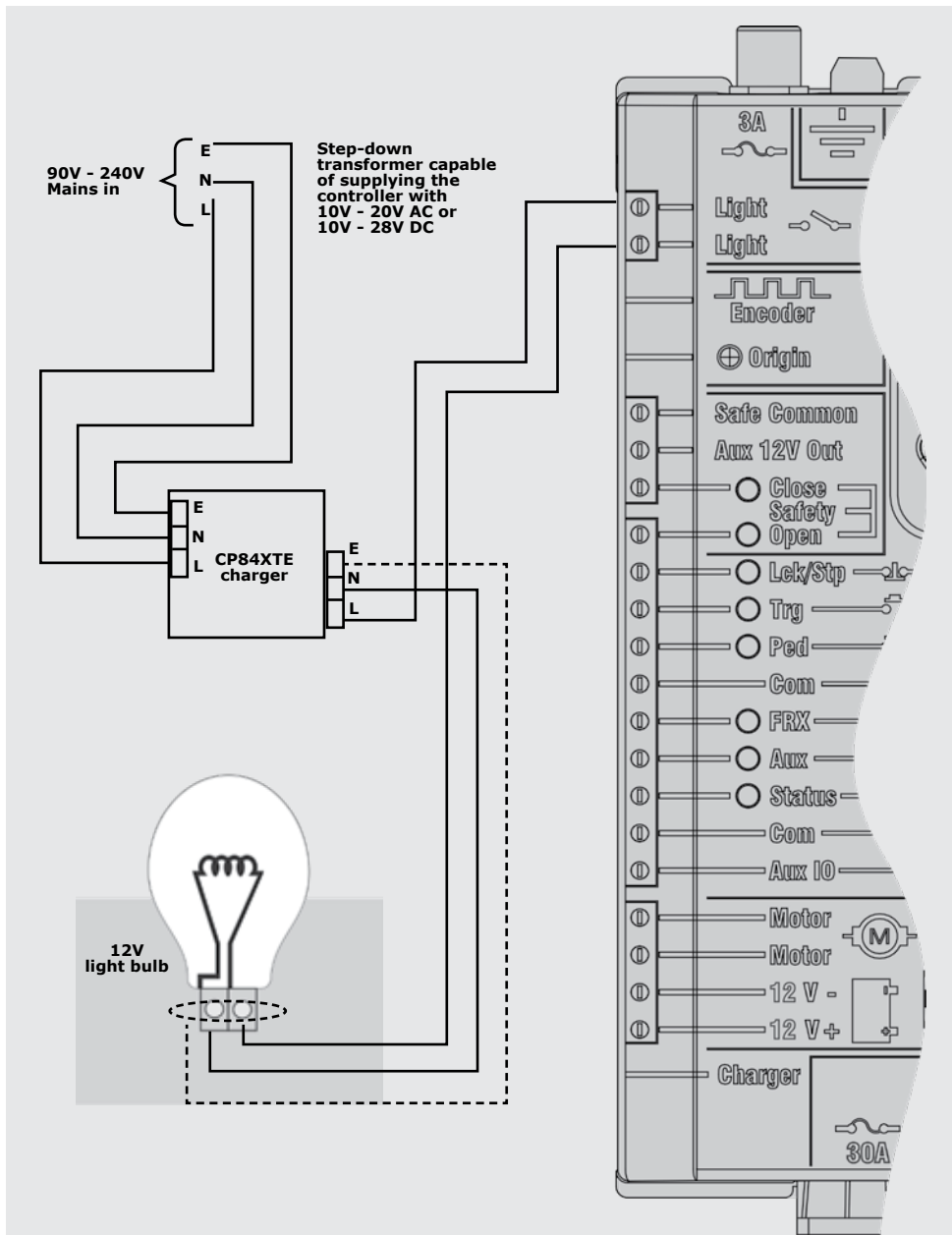

FIGURE 49

10.8. Earthing for Effective Lightning Protection

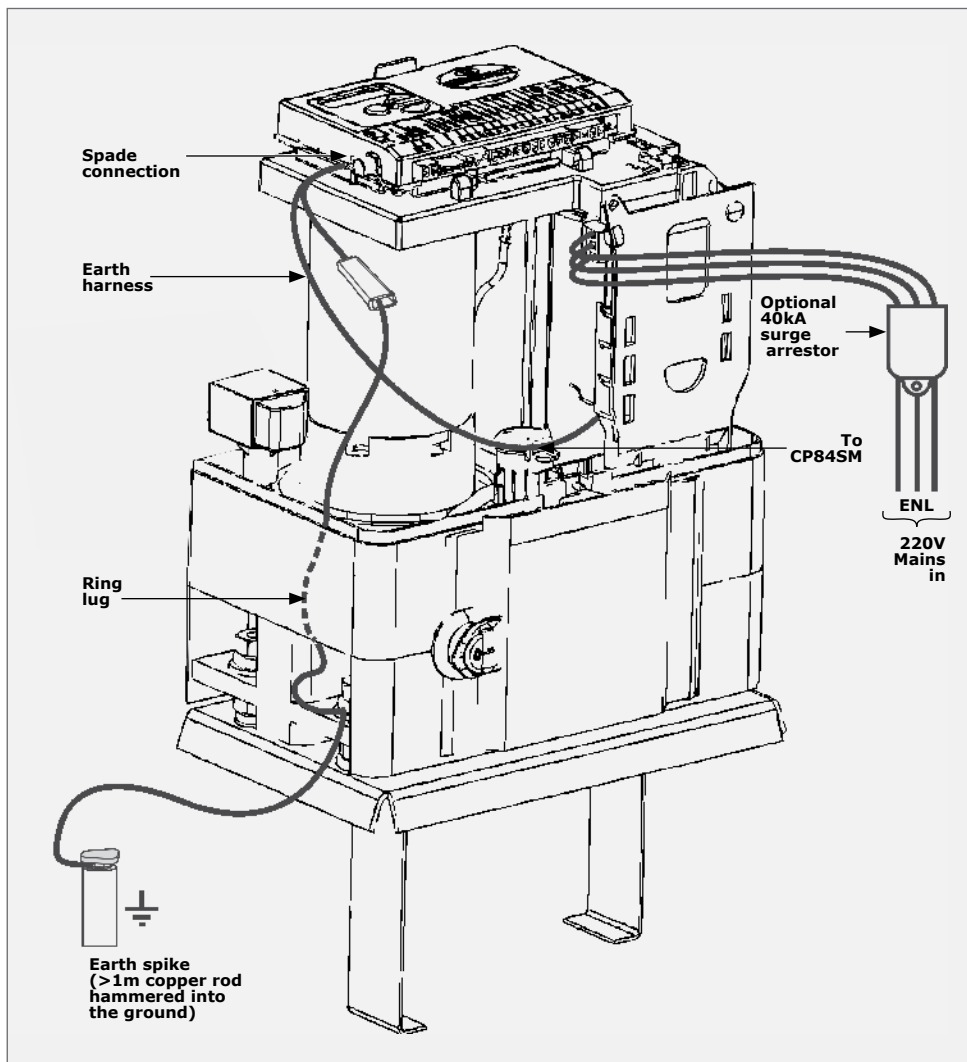

FIGURE 50

11. Commissioning the System

11.1. Setting the Gate Limits

1. Disengage the manual release lever, ensuring that the origin marker is correctly fitted. Move the gate to the middle of travel and re-engage the manual release lever.

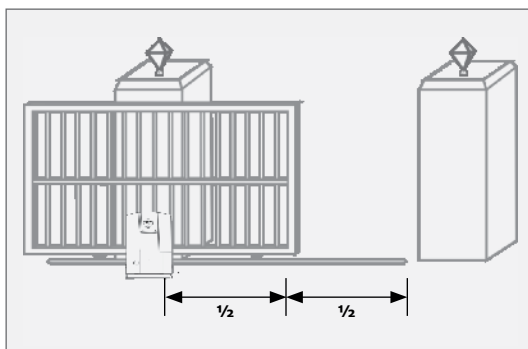

FIGURE 51

2. a) If powering up the system ex-factory, it will request for the operating Profile¹ (operating standard) to be set:

- ZA: Standard profile for South Africa
- CE: Standard profile for the European Union
- UL325: Standard profile for the USA

- b) Select the **Profile** that will suit the specific region from the list. With this set, the system will automatically proceed to the limit setup menu. Follow the onscreen instructions to complete the setup procedure.



FIGURE 52

- c) If powering up at any stage after this, push and hold the oblong **enter** button () for two seconds.

Select the "limits" menu by pressing the enter button (). Follow the onscreen instructions to complete the setup procedure.



1. For more details about the Profile (operating standard), refer to Section 15, Factory defaults schedule

12. How to set up additional features on the D5-Evo or D5-Evo Low-Voltage Controller

Section 13 provides the full menu of features that can be set up on the system. An explanation of each feature is provided in Section 14, Controller features.

When setting up the **D5-Evo or D5-Evo Low-Voltage** system via the LCD display, all the steps that have to be followed are clearly provided via the display. It is only necessary to note the following:

- To get into setup mode, press the enter (**■**) button for two seconds and follow the instructions provided from there
- The buttons provided on the controller for navigating the system are not marked because at each step during the setup, the function given to each button is provided on the display

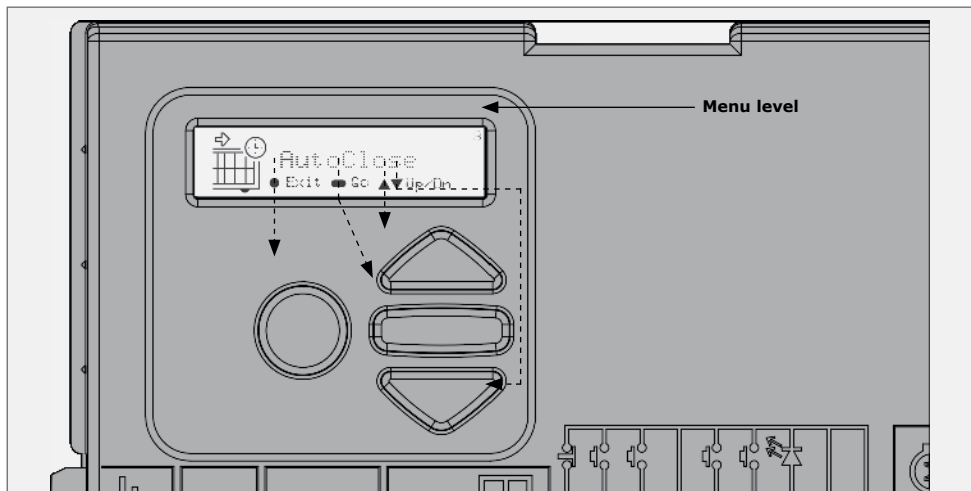

FIGURE 53

- When not in setup mode, i.e. normal mode, the (●) button is used as a **test** button for operating the system
- The triangular up or down (▲) buttons are used to scroll through the diagnostic screens
- For each feature, a factory default setting has been programmed into the controller. Referred to as an operating standard or profile, these defaults have been determined to suit the requirements of the specific region where the installation is being carried out. It is only necessary to change a feature where the default does not suit the installation. When selecting any feature in the menu, details of the current setting stored in the controller are displayed
- Refer to Section 15 for the Schedule of factory defaults for each feature

13. Menu Navigation Structure



1. Setting Limits



1.1. Setup wizard



2. Safety

2.1. Collision Force

- Opening Collision Force
- Closing Collision Force
- MTR S Opening Collision Force
- MTR S Closing Collision Force

2.2. Collision Count

2.3. Alarm Output

2.4. LCK Input as ESTOP

2.5. External gate indication

- Indicator Output
- Closed Indication
- Part Close Indication
- Closing indication
- Part Open Indication
- Opening Indication
- Open Indication
- Pedestrian Indication
- Unknown Indication



3. Autoclose

3.1. Autoclose Status

3.2. Autoclose Timer

3.3. Autoclose Override

3.4. Autoclose Advanced Options

- Autoclose Fully Open
- Autoclose Partly Open
- Autoclose Partly Closed



4. Modes of Operation

4.1. Operating Mode

- Standard Mode
- Condominium Mode
- Reversing Mode
- PLC
- Deadman Control Mode



5. Run Profile

5.1. Positive Close Mode

- Positive Close Mode Status
- Positive Close Mode Force

5.2. Pre-open Delay

5.3. Pre-close Delay

5.4. Opening Speed

5.5. Closing Speed

5.6. Ramp-Up Distance

5.7. Ramp-Down Distance

5.8. TRG Stop Distance

5.9. IRB Stop Distance

5.10. Crawl Distance



6. Infrared Beams

6.1. PIRAC Control

- PIRAC Status
- Stop on Open
 - Stop on Open Status
 - Stopping Distance

6.2. IR Beam Test

- Status

- Test Beam

6.3. IRBO=IRBC on Closing

6.4. IR Beam Alarms

- Ambush Alarm
- Break-in Alarm
- Alarm Output



7. Pedestrian

7.1. Pedestrian Open Position

7.2. Pedestrian Autoclose Time

7.3. Pedestrian pre-open Delay

7.4. Pedestrian pre-close Delay



8. Courtesy Light

8.1. Courtesy Light Timer

8.2. Courtesy Light Profile

- Courtesy Light
- Pre-flash A
- Pre-flash B
- Pre-flash C



9. ChronoGuard

9.1. Time and Date

9.2. Time-Periods

- Add Time-Period
- Delete Time-Period
- Edit review Time-Periods
- Auto Function
- Time-Bar

9.3. Exclusions

- Add Exclusion
- Delete Exclusion
- Edit Review
- Auto Function
- Time-Bar Function

9.4. Delete all Time-Periods and Exclusions



10. General settings

10.1. Operating Standard

10.2. Reset Options

- Factory Defaults
- Delete all Remotes
- Delete all Time-Periods and Exclusions
- Reset All

10.3. Diagnostic Screen Status

10.4. Test Button Disabled Status

10.5. Backup EEPROM

10.6. Restore EEPROM

CONTINUED OVERLEAF



11. Remote Controls



**Press button of valid remote control
(if menu locked)**

11.1.Add Remotes

11.2.Delete Remotes

- Delete Remote by ID
- Delete Remote Button
- Delete Remote by Button
- Delete not Present
- Delete all Remotes

11.3.Edit Remote Button

11.4.Autolearn

11.5.Lock Tx Menu

11.6.Onboard Receiver Enable/
Disable

14. Controller Features



14.1. Menu 2 - Safety (Collision Force)

14.1.1. Collision Force

If the gate is obstructed, the internal collision circuitry will activate. The response of the system to a collision will vary, depending on the profile selected (Operating Standard, eg. ZA). Responses can vary from the gate stopping, to the gate reversing. The **Collision Force** can be set from minimum to maximum in five discrete steps.

A sixth step will disable collision sensing entirely, allowing maximum force to be achieved. Under this condition, the motor will continue running until it stalls, at which point a collision will be detected.



This level should only be used if additional safety measures are taken (eg. Infrared Safety Beams, etc.).

Collision Force can be set independently per direction of travel.

14.1.2. Collision Count

A counter monitors the number of collisions that the gate experiences before it reaches the fully closed position. If the value exceeds the value set in the **Multiple Collision Counter**, the Controller shuts down until the next valid trigger is received. As an indication, the status LED will flash four times every two seconds. The **Multiple Collision** fault indication will continue to flash indefinitely or until a valid trigger has been received.

14.1.3. Alarm Output

After the preset collision count has been reached, an alarm is activated. The system can be configured to operate one of the following outputs provided on the controller:

- **Onboard buzzer** – emits a continuous tone
- **Pillar / Courtesy light contact** (potential-free normally-open contact, fuse-protected – 5A)
- **Aux IO** (this is an open collector drive, max current draw 3A, not fuse protected)
- **Safety beam common** (this is an open collector drive, max current draw 3A, not fuse-protected)
- **Status LED output** (operate up to three LEDs in parallel or interface with multi-LED driver card, CP78)

14.1.4. LCK input as ESTOP

Allows the Lck (Holiday Lockout) input to be configured as an emergency stop input. When activating the emergency stop, it will prevent the gate from moving, and, if it is moving, it will immediately stop.



14.2. Menu 3 - Autoclose

14.2.1. Autoclose Status

When enabled, the **Autoclose** feature has the function of automatically closing the gate after a preset **Autoclose** time. The **Autoclose** feature is **automatically** turned on when the Controller is set for **Condominium Mode**.

14.2.2. Autoclose Timer

The **Autoclose** time can be set anywhere from 1 to 255 seconds.

14.2.3. Autoclose Override

It is possible for the user to temporarily turn off **Autoclose** when the Mode of Operation is **Standard** or **Reversing**. To activate **Autoclose Override**, the Trg input must be activated and maintained for a period longer than the time set for the **Autoclose Override Time**.

The gate response will be to start opening on the Trg trigger, and then to stop as soon as the **Autoclose Override** time is reached. On clearing of the Trg input, the gate will continue opening until fully open. The **Autoclose** feature is now temporarily disabled and the gate will remain open indefinitely.

14.2.4. Autoclose Advanced Options

The conditions under which the gate will automatically close can be set within the **Advanced Autoclose** options menu:

- **Autoclose Fully Open** - automatically closes the gate if it has reached the fully open position
- **Autoclose Partly Open** - automatically closes the gate if it is stopped while opening, but before reaching the fully opened position
- **Autoclose Partly Closed** - automatically closes the gate if it is stopped while closing, but before reaching the fully closed position



14.3. Menu 4 - Modes of Operation

It is possible to select the following Modes of Operation: **Standard**, **Condominium**, and **Reversing Mode**. All modes are triggered by closing a normally-open contact between the Trg input terminal and the Com terminal.

14.3.1. Standard Mode

When stationary, a trigger impulse on Trg will cause the gate to either open or close. On a moving gate, a trigger impulse on Trg will stop the gate. The next impulse on Trg will cause the gate to reverse its direction of travel; i.e. the action is **start-stop-reverse**.

14.3.2. Condominium Mode

A trigger impulse on Trg will open the gate under all conditions. If it is closing, it will stop and reverse to open. In this Mode of Operation, the only way to close the gate is with the **Autoclose** feature, which is automatically activated when **Condominium Mode** is selected.

14.3.3. Reversing Mode

A trigger impulse on Trg will reverse the direction of a moving gate. If it is closing, it will stop and immediately begin opening. If it is opening, it will stop and immediately begin closing.



14.4. Menu 5 - Run Profile

14.4.1. Positive Close Mode (PCM)

Setting **Positive Close Mode** to ON will allow the gate to drive up hard to the closed endstop without causing the collision circuitry to operate. This feature operates only during the last few millimetres of gate travel in Closing Mode.

14.4.2. PCM Push Force

The amount of force applied by the motor when in PCM can be set as a percentage of full motor force.

14.4.3. Pre-Open Delay

Allows a delay between a valid trigger signal being received and the gate commencing movement in the opening direction. A warning light can be set to activate during this delay. (Refer to pre-flash modes of the pillar light feature, for more details).

14.4.4. Pre-close delay

Allows a delay between a valid trigger signal being received and the gate commencing movement in the closing direction. The delay will also occur if the gate is set to close automatically. A warning light can be set to activate during this delay. (Refer to pre-flash modes of the pillar light feature, for more details).

14.4.5. Opening speed

Sets the maximum opening speed in metres per minute. This can be set from 10 to 22 metres per minute. Selecting maximum will move gate at maximum possible speed.

14.4.6. Closing speed

Sets the maximum closing speed in metres per minute. This can be set from 10 to 22 metres per minute. Selecting maximum will move the gate at maximum possible speed.

14.4.7. Ramp-up Distance

Sets the ramp-up distance in centimetres of travel of the gate when starting. This can be set from 10 centimetres to 10 metres in 1 centimetre steps.

14.4.8. Ramp-down Distance

Sets the ramp-down distance in centimetres of travel of the gate when stopping. This can be set from 10 centimetres to 10 metres in 1 centimetre steps.

14.4.9. TRG Stop Distance

Sets the distance over which a moving gate will stop after a Trg input is received. This can be set from 10 centimetres to 1 metre in 1 centimetre steps.

14.4.10. IRB Stop Distance

Sets the distance over which a moving gate will stop after an infrared safety beam is broken. This can be set from 10 centimetres to 1 metre in 1 centimetre steps.

14.4.11. Crawl distance

Sets the final crawl distance in centimetres of travel of the gate when reaching an endpoint. This can be set from 10 centimetres to 10 metres in 1 centimetre steps.

14.4.12. Torque limit

Sets the maximum torque delivered by the motor. The maximum setting is a value of 15, while the minimum is four. This is useful in cases where limited push force is required.

I5 14.5. Menu 6 - IR beams



14.5.1. PIRAC

The **Passive-Infrared Autoclose** feature allows the gate to close automatically, as soon as a vehicle or pedestrian has passed through the Closing Beam.

This security feature ensures that the gate stays open for the minimum amount of time possible. If the **Autoclose** feature has been enabled, the system will react in the following way:

- When the gate is triggered to open and nothing moves through or interrupts the Closing Beam, the gate will open fully and stay open for the period of time determined by the **Autoclose Timer**
- However, if the Closing Beam is interrupted at any stage, while the gate is opening or open, the gate will close immediately after the Closing Beam is cleared



If the **Autoclose** feature has not been enabled then the gate will remain open indefinitely. To close the gate, the Closing Beam must be interrupted or the trigger button must be pressed

14.5.2. Stop on Open

If PIRAC is enabled, and a vehicle breaks the closing safety beam, the gate will by default, continue to open. If the gate is required to stop at this point, the Stop on Open function must be enabled. The stopping distance setting then determines in centimetres how far the gate will run on after the beam has been broken. The minimum setting is zero, which will cause the gate to stop immediately after the closing beam has been broken. The maximum setting is determined by the length of the gate.

14.5.3. PIRAC Override

The PIRAC feature can be temporarily disabled in the following manner:

- With the gate in the closed or partially closed position, press and hold the trigger button. The gate will begin to open and then stop. Continue holding the trigger button until the gate begins to open again
- Release the trigger button
- The gate is now in PIRAC Override Mode
- To re-enable the PIRAC feature, press the trigger button briefly
- The time taken for the gate to come to a stop is equal to the Autoclose Override time, or a minimum of two seconds if the Autoclose Override time is off
- The time taken for the gate to open again after it has come to a stop is approximately three seconds
- **Example:**

Autoclose Override time set to five seconds: Total time to temporarily disable the PIRAC feature is approximately eight seconds (5s + 3s = 8 seconds)

Autoclose Override time set to off: Total time to temporarily disable the PIRAC feature is approximately three seconds

14.5.4. IR Beam Test

(Only compatible with i5 Safety Beams; not compatible with Photon wireless Safety Beams).

Automatically tests the Safety Beams before each gate cycle. (eg. as required by CE.) In order for this feature to work, the power supply negative of the beam transmitter must be wired to the Safe Com terminal of the Controller.

14.5.5. IRBO=IRBC

Configures the opening beam to act as a closing beam while the gates are closing.

14.5.6. IR Beam Alarms

This feature allows the following alarms:

14.5.6.1. Ambush Alarm

Activates an alarm if either the Opening or Closing Beams have been continuously interrupted for a pre-defined time. The alarm will remain activated while the beams are interrupted.

For example, if a would-be intruder covers the **Safety Beams** so that when the gate is opened, the gate will stay open, the system will detect this beam override taking place and set off an alarm.

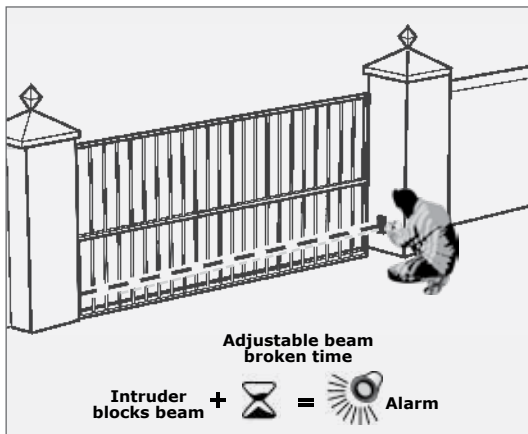

FIGURE 53

14.5.6.2. IR Beam Broken Time

The time that the Beams must be interrupted before the ambush alarm is activated.

14.5.6.3. Break-in Alarm

Activates an alarm if the Closing Beam on the outside of the property is interrupted while the gates are closed. The alarm remains activated while the Beams are broken, and for a period of 30 seconds thereafter. This time is fixed. Only active when gate is fully closed.

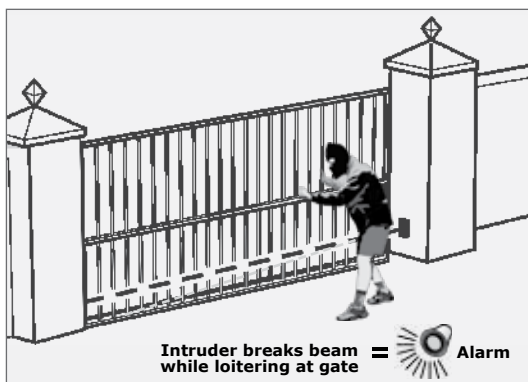

FIGURE 54



If this break-in alarm is used, it is recommended that TWO parallel Closing Beams be used to reduce the chance of false triggering.

14.5.6.4. Alarm output

The system can be configured to operate one of the following outputs provided on the Controller:

- **Oboard buzzer** - emits a continuous tone
- **Pillar / Courtesy Light contact** (potential-free normally-open contact, fuse-protected - 5A)
- **Aux IO** (this is an open collector drive, max current draw 3A, not fuse-protected)
- **Safety beam common** (this is an open collector drive, max current draw 3A, not fuse-protected)
- **Status LED output** (operate up to three LEDs in parallel or interface with multi- LED driver card, CP78)



14.6. Menu 7 - Pedestrian Opening

This feature is associated with the PED input on the Controller. When activating this input, the system will open the gate to the Pedestrian Open position, and then automatically close after the **Pedestrian Autoclose** time lapses. If the **PED** connection to Com is maintained, then the gate will remain open, and when the connection is broken, it will close after the **Pedestrian Autoclose** time has expired.

The time taken for the gate to open to pedestrian is dependent on the pedestrian **Pre-open Delay** and the time required for the gate to close from the pedestrian position is dependent on the **Pedestrian Pre-close Delay**.

14.6.1. Pedestrian Open Position

Sets the maximum opening of the pedestrian gate in metres, in one centimetre steps.

14.6.2. Pedestrian Autoclose Time

Sets the Autoclose time in seconds after the Pedestrian Opening. This time can be set from zero seconds to four minutes in one second steps.

14.6.3. Pedestrian Pre-open Delay

Sets the time delay between the Pedestrian Opening input being activated, and the gate actually opening. This enhances safety in cases where the pedestrian has to reach through the gate in order to activate the pedestrian input. This delay can be set from zero seconds to four minutes in one second steps



A **Warning Light** would typically be active during this delay.

14.6.4. Pedestrian Pre-close Delay

Sets the time delay between the **Pedestrian Autoclose** timer expiring, and the gate actually closing. This delay can be set from zero seconds to four minutes in one second steps.



- A **Warning Light** would typically be active during this delay
- The **Warning Light** is any light wired to the **Pillar Light** contacts, as described in Menu 8



14.8. Menu 8 - Courtesy/Pillar Light

This feature is associated with the **Light** connections on the Controller. Refer to Page 42 and 43 of the manual for details on how to connect a Pillar or security light to the Controller.

The Pillar Light circuit has multiple functions:

- It operates as a **Courtesy Light** and switches on for a selectable time period every time the gate is activated
- The **Courtesy Light** can also be turned on for the same time period by momentarily connecting the LIT terminal to the Com terminal via a pushbutton
- The **Courtesy Light** can also be turned on permanently by connecting the LIT terminal to the Com terminal via a pushbutton, for three seconds.

A short pulse thereafter will switch the lights off. The status LED will flash once every two seconds to indicate that the Courtesy Light is on permanently. The abovementioned facility can also be achieved via a remote learned to the system and mapped to the **Courtesy Light** function from within the remotes menu



The gate will not open when using the **LIT** input.

- When the **PED** input is triggered, the **Courtesy Light** flashes for an adjustable pre-flash time (0 to 255 seconds), before the pedestrian gate opens.

14.8.1. Courtesy Light Time

The time that the Courtesy Light will remain activated can be set from four seconds to ten hours in one second increments.

14.8.2. Light Profile

The Courtesy Light can be selected to operate according to one of the following:

- Courtesy Light as explained earlier
- Pre-flashing Mode

- If Pre-flashing Mode A, B or C is selected, the behaviour of the Courtesy Light will be as follows:
 - Mode A will **turn on** the Courtesy Light only while the gate is moving
 - Mode B will **flash** the Courtesy Light during the Pre-opening and pre-closing Delays, as well as while the gate is moving
 - Mode C will **turn on** the Courtesy Light during the Pre-opening and Pre-closing Delays, as well as while the gate is moving
 - In these Pre-flashing Modes, the timed Courtesy Light functionality is not available



14.9. Menu 9 - Chronoguard (TimePeriods)

ChronoGuard™ (a world first) is a powerful feature which has been added to the new generation controllers. An integral Real Time Clock (RTC) is used to provide time-based functionality, including the automatic activation or time-barring of specific controller inputs, and the time-barring of specified remote control buttons used together with the onboard NOVA rolling code-hopping.

The RTC will keep time for a minimum of one hour without any power.

14.9.1. Time-periods

A Time-period is defined by a start and end date and time. Up to one hundred Time-periods can be defined. A Time-period can be a once-off event, or can be set to repeat on a weekly or annual basis. The weekly repeat can be chosen to occur on every day of the week, weekdays only, weekends only, or any specific day. The minimum duration of a time period is one minute. Once-off Time-period have the highest precedence, followed by annual and then weekly. When appropriate, a "Tp" icon will appear on the display to indicate that a Time-period is active.

14.9.2. Auto activations (Auto function)

The following controller inputs can be set to activate automatically during a Time-period:

- Free-exit (FRX)
- Pedestrian opening (Ped)
- Holiday Lockout (Lck)
- Closing beam (IRBC)
- Courtesy light control (Aux)

During the relevant Time Period, the selected input will be activated. Where appropriate, the diagnostic LED of the relevant input will illuminate.

The following controller output can be set to activate automatically during a Time-period:

- Auxiliary output (Aux IO)

14.9.3. Time-barring

Time-barring of inputs is divided into physical inputs and RF inputs (inputs mapped to a NOVA code-hopping transmitter button).

The following physical inputs can be time-barred (prevented from operating) during a Time-period:

- Trigger (Trg)
- Pedestrian opening (Ped)
- Free-exit (FRX)
- Holiday Lock (Lck)
- Courtesy light control (Aux)

The following physical outputs can be time-barred (prevented from operating) during a Time-period:

- Courtesy (pillar) light relay (Light)
- Auxiliary output (Aux IO)

The following RF inputs can be time-barred (prevented from operating) during a Time-period:

- Trigger (Trg)
- Pedestrian opening (Ped)
- Free-exit (FRX)
- Holiday Lock (Lck)
- Courtesy light control (Aux)
- Exclusions



- Time-barring of a NOVA code-hopping transmitter is specified at the time of coding the transmitter into the system. Once an RF input is defined as time-barred, any time-barred transmitter associated with that input will be time-barred during the relevant Time-period
- If a physical or RF input is currently time-barred, any attempt to activate it will be acknowledged by a short beep of the onboard buzzer. The input, however, will not activate

Exclusions are used to prevent scheduled Time Periods from occurring at specific times (e.g. public holidays). While time-barring can be used to achieve a similar end, exclusions can also be used to exclude time-barring itself. Each exclusion consumes one Time-period. Exclusions have the highest precedence, followed by time-barring and then auto-activations (auto function).



14.10. Menu 10 - General Features

14.10.1. Operating Standard

Regional Operating Standards can be set. Applying this setting will automatically configure the Controller settings to conform to the specific region's standard. (eg. UL325, CE or 2A.)

14.10.2. Reset Options

The Controller settings can be reset through the **Reset Options** menu. Various reset options are available:

- **Factory Defaults** - All settings will be restored to the default values dictated by the Operating Standard/Profile that is currently selected. **All remote controls and gate limits will not be affected**
- **Delete All Remotes** - Delete all the remotes stored in the system; **no settings affected**
- **Delete all Time-Periods** - All auto-activation (auto function) and time-bar functions are deleted or removed
- **Reset All** - Clears and defaults the system completely. Unit will be reset to the **Factory Default** settings in addition to clearing all **remotes** and **time periods**

14.10.3. Diagnostic Screen

Allows a diagnostic screen to be displayed. This can be useful when troubleshooting, but requires some technical knowledge.

14.10.4. Round Test Button

Allows the round test button on the Controller to be disabled, in cases where higher security is required.

14.10.5. Backup EEPROM

Allows all controller settings, remote controls and Time-period functions to be backed up. Requires a backup module, obtainable from Centurion Systems (Pty) Ltd.

14.10.6. Restore EEPROM

Allows all controller settings, remote controls and Time-period functions that have previously been backed up, to be restored. Requires a backup module, obtainable from Centurion Systems (Pty) Ltd.



If the backup module is used to restore the settings of a different **D5-Evo or D5-Evo Low-Voltage** operator, then the gate limits setup procedure must be performed again.



14.11. Menu 11 - Remote Controls

The controller is capable of learning up to 500 NOVA code-hopping remote control buttons. Each transmitter can have up to four buttons.

Benefits of the Shift Button system:

- It is possible to artificially increase the number of buttons of a multi-button remote control by using a two-button combination
- One of the buttons is used as a **Shift Button** to allow the other buttons to be used again in combination with this button. In other words, the user will press and hold the **Shift Button**, before pressing one of the other buttons to create a **new** button
- The **Shift Button** cannot be used as a button on its own, it must always be used in combination with the other buttons



Benefits of the Shift Button system:

- Use of the **Shift Button system** allows a three-button remote control to gain an extra button and operate four functions and likewise a four- button remote control gains two extra buttons and can operate six functions
- Another benefit of using the **Shift Button system** is that it **requires both hands to operate the two-button combination**. This prevents the user from accidentally enabling sensitive functions such as Holiday Lockout on the Controller



14.11.1. Press Valid Button

If the **Remote Controls Menu** has been locked as discussed later, only by pressing a button of a remote control learned into the system, can the Remote Controls Menu be accessed.

14.11.2. Add Remote

Any button can be set to control the **Trigger, Pedestrian, Free-exit, Holiday Lockout** or **Courtesy Light Control (LIT)** inputs. When adding remote controls, it is recommended that a record be kept of the ID number allocated by the system to each respective remote control and the person to whom the remote control is given. This is necessary should selective deletion be required at a later stage.

14.11.3. Delete Remote

Remote controls can be deleted at any stage according to one of the following methods:

- **Delete Remote by ID**
Each remote control can be deleted individually according to its unique ID. To facilitate this, a record of the ID and the person to whom the ID has been assigned must have been made at the time of learning the remote control into the system. The remote control is not required for this operation

- **Delete Remote Button**
The operation of a button of a particular remote control can be deleted. For example, it allows the Holiday Lockout function set on one remote button of a remote control to be cleared, without affecting the other operations that the same remote control performs. The remote control is required for this operation
- **Delete Remote by Button**
Use this procedure to remove the remote control from the system. All button functionality will be removed. The remote control is required for this operation
- **Delete not Present**
Allows for transmitters that have not been used within a selectable time period to be removed from the system. The Time-period can be set from one hour to seven days, in one hour increments.

14.11.4. Delete all Remotes

Clears the entire memory. All transmitters will be removed.

14.11.5. Edit Remote Button

Change the function on one remote to perform another function. For example, button one's function is to open the gate completely. To change this, use edit remote button, select PED, and button one of the same remote will now only open the gate to the pedestrian setting.

14.11.6. Autolearn

Allows a selectable Time-period to be set, during which any specific button, when pressed, will be learned to a specific function. The function itself will also be activated when the button is pressed. After the Time-period has expired Autolearn is disabled, and no further buttons will be learned. The Time-period can be set from one hour to seven days in one hour increments.

14.11.7. Tx menu Locked

Allows the remote controls menu to be locked, preventing the unauthorised addition of new transmitters to the system. Once enabled, the remote controls menu can only be accessed by pressing a valid transmitter button.

14.11.8. Onboard receiver

The onboard NOVA code-hopping receiver can be disabled in the unlikely event that it causes interference with an existing external receiver.

15. Factory Defaults Schedule

15.1. South African Standard Profile - ZA

Parameter Description	Unit	Minimum	Default	Maximum
Menu 1 - NA				
Menu 2				
Opening Collision Force	Level	1	3	Max
Closing Collision Force	Level	1	3	Max
Collision	Collisions	1	4	255
Alarm Output	B CL SC XIO LED		B	
LCK ESTOP	Yes or No		No	
Menu 3				
Autoclose status	On/Off		Off	
Autoclose timer	mm:ss	00m:00s	00mm:15s	04m:00s
Autoclose override time	mm:ss	00m:00s	00m:03s	04m:00s
Autoclose from fully open	On/Off		On	
Autoclose from partly open	On/Off		On	
Autoclose	On/Off		Off	
Menu 4				
Modes	S, C, R, P, D		S	
Menu 5				
PCM Status	On/Off		Off	
PCM Force	%	10%	30%	100%
Pre-open delay time	mm:ss	00m:00s	00m:00s	01m:05s
Pre-close delay time	mm:ss	00m:00s	00m:00s	01m:05s
Opening speed	m/min	10m/min	Max	Max
Closing speed	m/min	10m/min	Max	Max
Ramp-up distance	m	0.1m	0.2m	10m
Ramp-down distance	m	0.1m	0.2m	10m
TRG stop distance	m	0.1m	0.25m	1m
IRB stop distance	m	0.1m	0.17m	1m
Crawl distance	m	0.01m	0.03m	1m
Torque limit	A	4A	15A	15A

TABLE 3

1. STD, REV, CON (Modes of Operation) - Standard, Reversing, Condominium
2. PCM - Positive Close Mode
3. POM - Positive Open Mode



15.1. South African Standard Profile - ZA (continued)

Parameter Description	Unit	Minimum	Default	Maximum
Menu 6				
PIRAC control	On/Off		Off	
Stop on open	On/Off		Off	
Stopping distance	m	0m	0.1m	9.99m
IR beam test	On/Off		Off	
Test beam	IRBC/IRBO/both		IRBC	
Ambush alarm	On/Off		Off	
Ambush time	hh:mm	00h:01	00h:01m	04h:00m
Break-in alarm	On/Off		Off	
Alarm output	B,CL, SC, XIO, LED		B	
Menu 7				
PED opening	m	0.05m	1m	see note
PED pre-open delay	mm:ss	00m:00s	00:05s	04m:25s
PED pre-close delay	mm:ss	00m:00s	00m:00s	04m:00s
Menu 8				
Light timer	h:mm:ss	0h:00m:04	0h:02m	9h:59m:
Light profile	CL, PFA, PFB, PFC		CL	
Menu 9 - NA				
Menu 10				
Diagnostic screen	On/Off		On/Off	
Round test button	On/Off		On	
Menu 11				
Delete not present	On/Off		Off	
Autolearn	On/Off		Off	
Tx Menu Lock	On/Off		Off	
Onboard receiver	On/Off		On	

TABLE 3. CONTINUED

4. CLS, OPN, BTH - Closed Position, Open Position, Both (Open & Closed Positions)
 5. CUR, PFA, PFB, PFC - Courtesy, Profile A, Profile B, Profile C

16. Description of Terminal Functions

12V+	Positive battery connection.
	 Battery terminal normally indicated as + or red (right-hand battery)
12V-	Negative battery connection.
	 Battery terminal normally indicated as - or black (left-hand battery)
Motor	Motor Output - connects to the thick blue motor wire
Motor	Motor Output - connects t the thick black motor wire
Aux IO	<p>The Aux IO terminal provides an open collector output which can be used for alarm or auto function purposes. If the collision alarm output or the IRB alarm output has been configured to Aux IO, then the negative of the alarm device must be connected to this terminal. The positive of the alarm device must be connected to the Aux 12V Out terminal. Similarly, if Aux IO is auto-activated via a ChronoGuard auto function Time-period, the device being switched (typically a 12V relay) must be powered from the Aux 12V Out terminal, and have its negative switched by Aux IO. If the Aux IO has not been selected as either an alarm indicator output or auto-activated output, the Aux IO terminal will behave as a Com termination point. All trigger signals, etc., have their return path to one of the Com terminals.</p>
Com	The common termination point. All trigger signals, etc. have their return path to one of the om terminals.
Status	<p>External gate status indicator. (A low-current output signal.) An output terminal which provides a low current, drive (approx. 4,5V DC, 20mA) to a LED which can be used to indicate the gate status remotely. If more than three LEDs are required it is necessary to fit the CP78 multi-LED driver card. For more details on the feedback about the status of the gate provided by the status LED refer to Section 17.</p>
Aux	<p>Activates the Pillar Light Relay. (A normally-open potential-free input). Momentarily connecting this input to Com will cause the light relay to energize for a period of time as set in the courtesy light timer menu. If the connection is made for a period exceeding three seconds the pillar light relay will latch and remain latched indefinitely until a new momentary connection to Com is given.</p>
FRX	<p>Free-exit input. (A normally-open potential-free input). Momentarily connecting this input to Com will cause a gate which is closed, or closing, to open or re-open. If the gate is open, or opening, the signal has no effect other than to reset the Autoclose timer (if selected). Free-exit (FRX) never initiates a closing cycle. The only way to close a gate, if only the FRX input is used, is to activate the Autoclose feature on the controller.</p>

Com The common termination point. All trigger signals, etc. have their return path to one of the Com terminals.

PED Pedestrian opening input. (A normally-open potential-free input). Momentarily connecting this input to COM will cause the gate to open to the pedestrian open position. For more information refer to the pedestrian feature in Section 14.

TRG Trigger input. (A normally-open potential-free input.) Momentarily connecting this input to COM will cause the gate to open, close or stop, depending on the operating mode selected. For more information, see the Autoclose feature and Modes of Operation.

LCK/STP Holiday Lockout or gate stop input. (A normally-closed potential-free input). For as long as a connection between this input and COM is maintained the controller will behave normally, but when this connection to COM is broken all inputs are inhibited.



- If this input is enabled while the gate is moving or in the open position, it will only activate and inhibit operation of all the inputs when the gate is back in the closed position
- This input can be configured as an emergency stop input. Refer to Section 14, Menu 2 for details



If the Lck function is not required a link must be fitted between LCK and COM¹(refer to note on page 68)

Safety Open

Opening beam safety input. (A normally-closed potential-free input). As long as a connection between this input and Common is maintained the controller will behave normally. When this connection is broken it will prevent the gate from opening if it is stationary, and will stop and close the gate if it is opening. This input has no effect if the gate is closing.



If the Safety Open and reverse functions are not required a link must be fitted between Safety Open and Safe Common for the controller to operate normally¹

Safety Close

Closing beam safety input. (A normally-closed potential-free input). As long as a connection between this input and Common is maintained, the controller will behave normally. When this connection is broken, it will prevent the gate from closing if it is stationary, and will stop and open the gate if it is closing. This input has no effect if the gate is opening.



If the Safety Close function is not required a link must be fitted between Safety Close and Safe Common for the controller to operate normally¹

Aux 12V Output

Auxiliary power connection. Provides +12V DC supply for auxiliary equipment such as a radio receiver, photo cells, etc. It is electronically limited to 1A.

Safe Common

Used for switching the power supply to the safety beams. If automatic beam testing is required, the negative power supply connection of the beam transmitter only must be wired to this point. In addition, the beam test circuit must be switched on via Menu 6. See Section 14

Light/light

Pillar light connection. These two terminals provide a normally-open potential-free contact which is generally used to switch on a pillar light (courtesy light). This contact is fuse-protected – refer to Section 3 for fuse specifications.



1. When setting up the controller for the first time or after a full reset back to factory default, has been performed, the system will electronically override the Safety Inputs and allow the system to function without the links. However, if safeties are connected to either or both inputs thereafter, there must be a normally-closed circuit maintained for the system to operate correctly. i.e. if beams are fitted and then removed, the circuit which is affected must be replaced with a wire link to create the normally-closed circuit.

17. Diagnostics

17.1. Diagnostic LEDs

The **D5-Evo or D5-Evo Low-Voltage** controller has a series of diagnostic LEDs which indicate the state of the inputs.

Normally-open inputs are indicated by a red LED, and normally-closed inputs by a green LED. An illuminated red LED indicates that the signal is present (e.g. intercom button pressed), while a non-illuminated green LED indicates that the signal is absent (e.g. IRB broken).

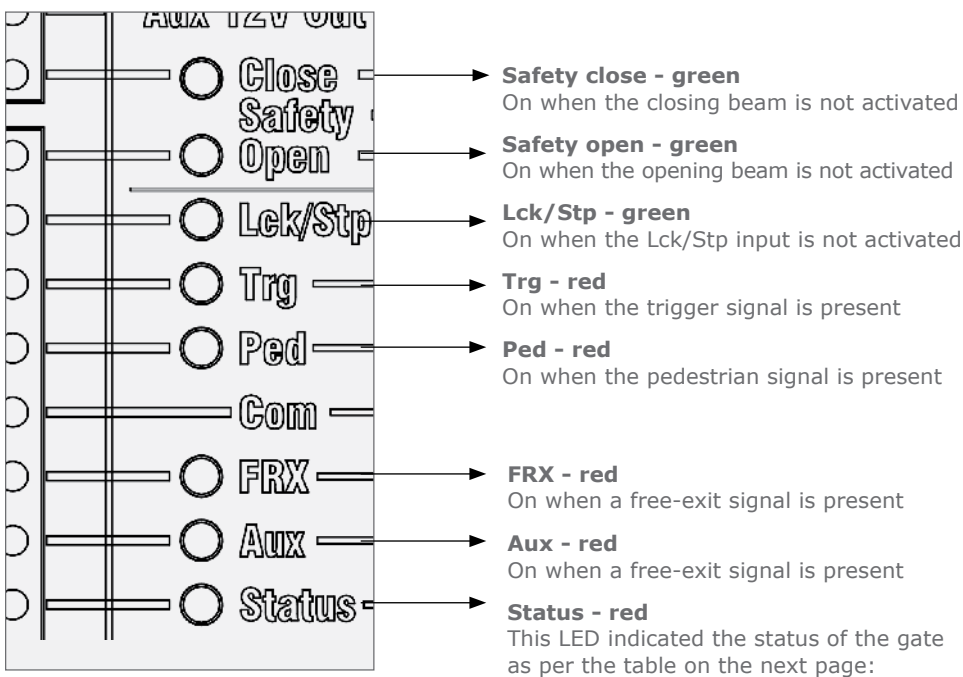

FIGURE 55

17.2. Gate Status LED Indication

Off	Gate is closed
On	Gate is partially or fully open
Continuous slow flash	Gate is opening
Continuous fast flash	Gate is closing
One flash every two seconds	Pillar light override is activated
Two flashes every two seconds	No mains present
Three flashes every two seconds	Battery voltage is low

TABLE 4

17.3. LCD Display

The LCD display shows useful information regarding the status of the system

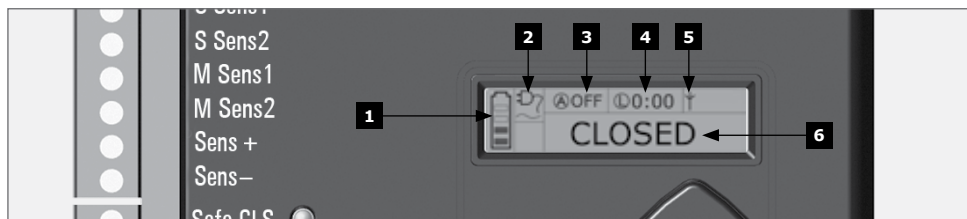

FIGURE 56. CONTROLLER SCREEN

17.3.1. Battery icon

Indicates the state of charge of the battery:

- Four solid bars = full capacity
- Two solid bars = 50% capacity
- No solid bars, with the icon flashing = battery empty

17.3.2. Mains icon

Displays the presence/absence of mains voltage:

- Plug solid = mains present and battery charging
- Plug hollow and flashing = no mains present and battery not charging

17.3.3. Autoclose information

- Displays the state of the Autoclose function
- Displays off if Autoclose is not selected
- OVR if Autoclose is overridden
- Remaining Autoclose time if Autoclose is active
- POVR indicates that the PIRAC option is overridden

17.3.4. Pillar Light information

- Displays the remaining light time if Courtesy Light Mode is selected
- Pre-flashing Mode is displayed if Pre-flash is selected
- LIT will be indicated if the Pillar Light has been turned on permanently

17.3.5. Onboard receiver information

Displays the current input being activated by the onboard receiver

17.3.6. Status information

Displays useful information regarding the status of the gate

17.4. Buzzer Feedback

A warning buzzer will sound (where applicable) as per the table below:

Inhibitor name	Priority	Number of beeps	Fault type	Gate continues to operate	User can correct error
Break-in Alarm	1	Continuous tone for 30 seconds	Alarm	N/A	N/A
Ambush Alarm	2	Continuous tone until IRBs are cleared	Alarm	N/A	N/A
Battery-low	4	3 beeps periodically for 30 seconds	Power system fault	Yes ¹	Yes
Multiple Collision	3	Periodic until condition is cleared by user (500/500ms)	Collision	No	Yes
Auxiliary overload	5	5 beeps periodically for 30 seconds	Hardware	No	No
Holiday Lockout	6	1 beep periodically for 30 seconds	User	No	Yes
Emergency stop	7	1 beep periodically for 30 seconds	User	No	Yes
Time-barring	8	1 beep periodically for 5 seconds	User	No	Yes
No limits set	9	3 short beeps for 5 seconds	User	No	Yes
Mains failure	10	2 beeps periodically for 30 seconds	Power systems fault	Yes	Yes
Beams broken(any)	11	1 beep periodically for 30 seconds	User	No	Yes
Beams failure	12	5 beeps periodically for 30 seconds	Hardware	No	Yes
DOSS disconnected	13	5 beeps periodically for 30 seconds	Hardware	No	No

1. Gates will close fully and then shut down for two minutes

TABLE 5

Inhibitor name	Priority	Number of beeps	Fault type	Gate continues to operate	User can correct error
Fuse blown	14	5 beeps periodically for 30 seconds	Hardware	No	Yes
Motor disconnected	15	5 beeps periodically for 30 seconds	Hardware	No	Yes
Bridge damaged	16	5 beeps periodically for 30 seconds	Hardware	No	No
Gate stalled	17	4 beeps periodically for 10 seconds	Collision	No	No
No magnet detected	18	Periodic until condition is cleared by user (500/500ms)	Lost	Yes	Yes

TABLE 5

18. Fault-finders Guide

Problem	Possible faults
Gate does not move	<ul style="list-style-type: none"> • Fuse is blown – Check 30A ATO fuse, and replace if necessary • Lck (Holiday lockout) input activated. Green Lck light should be on • IRBC/IRBO (IR beams) inputs activated <ul style="list-style-type: none"> • IRBC - gate will not close once open; IRBO - gate will not open once close • Green IRBC/IRBO lights should be on - check cabling and Aux 12V Out • Latching input on TRG or FRX • Both TRG and FRX lights must be off for gate to operate • Check for an auto-activation (auto function) on FRX and Trg inputs. Refer to diagnostic screen with matrix showing different auto-activations (auto function) and time-barring functions on the different inputs • Check the battery condition with procedure A: Low battery voltage condition, later in this section • If status light flashes four times or there is a “Max Collisions” indication on the LCD display, then the operator is in Multiple Collision Mode. If required, check with procedure B: False collision detection, later in this section • If the problem persists, the main controller might be faulty
Gate moves a short distance, and then stops	<ul style="list-style-type: none"> • Check the battery condition with procedure A: Low battery voltage condition, especially if the status light flashes three times or there is a “Battery Low” indication on the LCD display • Check for false collisions with procedure B: False collision detection, later in this section (status light could also flash four times if the number of detected collisions exceeded the Collision counter feature value) and LCD indicates “Max Collisions” • Intermittent IRBC/IRBO signals. Check that the voltage applied to the beams is appropriate • Spurious trigger. Intermittent short due to possible moisture on the FRX or Trg inputs. Monitor FRX or Trg LED’s • If the problem is still not solved, the main controller might be faulty
Gate starts closing, then stops and re-opens	<ul style="list-style-type: none"> • Check collision sensitivity and other causes with procedure B: False collision detectio

Problem	Possible faults
<p>Gate repeatedly overrides its end-of-travel limits</p>	<ul style="list-style-type: none"> • Besides a faulty controller, which will be considered last, the only components that could cause this symptom are a missing origin, or and most unlikely, a faulty DOSS sensor • However, initially before the gate overrides its limits, if the origin is not detected, the controller will automatically start beeping when the gate is running, but it will allow normal operation • Check for the following: • Check that the origin marker is correctly positioned as shown on pages 33 to 34 • Check if the gate origin has accidentally moved. If so, reset the limits as directed on page 35 • Check that the DOSS sensor harness is properly plugged into the magnetic origin switch, the DOSS sensor and the controller • Carefully check the condition of the harness - look out for any bad crimp joints between the wires and the connectors on the harness • Check that the magnetic origin switch is mechanically switching. While in manual mode, slide the gate backwards and forwards so that the magnet passes the switch each time. Listen out for a distinctive click as the switch operates. Also confirm the direction of the magnet using the relevant diagnostic screen (e.g. magnet on the left or magnet on the right) • Check that the magnetic origin switch is securely clipped into the housing • Unclip and lift out the DOSS sensor and check that there is no evidence of oil on the sensor eyes or ant/dirt ingress • If the problem is not solved, the main controller might be faulty
<p>Unreliable autoclose</p>	<ul style="list-style-type: none"> • Latching receiver on Trg would activate the Autoclose Override feature • Long pulse on Trg would activate the Autoclose Override feature. • Faulty IRBC Beam signal • Intermittent power loss, check for low voltages with procedure A: Low battery voltage condition • If the problem is still not solved, the main controller might be faulty

Problem	Possible faults
Gate opens to pedestrian and closes	<ul style="list-style-type: none"> • Intermittent fault on Ped (Pedestrian) input. Check wiring, and keyswitch/keypad operation • Check Procedure B: False collision detection • If the problem is still not solved, the main controller might be faulty
Gate takes a few seconds before it opens to pedestrian	<ul style="list-style-type: none"> • By default the motor would delay opening to pedestrian for two seconds. This time can be changed by altering the value of the Pedestrian pre-open delay feature - refer to Section 21, Menu 7.3
Gate opens to pedestrian and stays open	<ul style="list-style-type: none"> • There is a continuous Ped signal; the Ped light will be on continuously. (The Ped light and signal must turn on momentarily for the gate to close after a pedestrian signal) • The Pedestrian feature operated via the onboard receiver could have been inadvertently set to be latching. Refer to the remotes diagnostic screen for assistance • If an external receiver is operating the Pedestrian input, check for an accidental latching contact , or a faulty keyswitch/ keypad • If the problem is still not solved, the main controller might be faulty
Gate opens from the intercom, but not via remote control	<ul style="list-style-type: none"> • The fault is with the receiver • Internal receiver could be locked • Check remotes are correctly learned to the receiver. Refer to remotes diagnostic screen for verification • The onboard receiver could be faulty • If an external receiver is used, check: <ul style="list-style-type: none"> • the wiring between the receiver and control card • that the receiver has power • that the receiver is not faulty • that the remotes are learned correctly to receiver

18.1. Procedure A - Low battery voltage condition

Status light flashes three times – LCD indicates “Battery Low”

If the battery voltage is less than 13.5V, the motor would not operate at all. For any other voltage, the battery could still be the cause of the problem. Is the battery being properly charged?

- Check the “mains present” icon on the main diagnostic screen or switch to the battery charger diagnostic screen and check the charger voltage – right-hand value. This should indicate approximately 13.8V
- Check that the mains power is turned on (measure 230V AC on the mains connector for the D5-Evo, or 15-19V AC / 12 - 26V DC for the D5-Evo Low-Voltage)
- Check that the red LED on the side of the charger is lit
- Check the charger’s supply fuse (D5-Evo charger – 3A)
- Check that the white battery charger connector is making proper contact
- Check the condition of the battery leads, terminals and connectors. Look for and correct all loose connections and signs of corrosion
- The battery might be discharged. Measure the battery voltage with the charger connected, if the voltage is below 13.5V then the battery is discharged. The number of opening cycles per hour may be excessive, thus discharging the battery. Refer to the Trip Counter diagnostic screen for assistance. Charge the battery if required
- Charger might be faulty. Disconnect the battery, and measure the voltage on the battery leads. It must be between 13.6V and 13.8V. If not, replace the charger
- Battery might be old, and might have to be replaced. If in doubt, test as follows:
 - Check that the battery is charged, by ensuring that the battery voltage is above 13.5V with the charger connected. (If the battery is in a good condition it would probably pass the test without being fully charged)
 - Disconnect the charger from the battery
 - Remove the DC Motor leads from the DC Controller
 - Apply the DC motor leads directly to the battery, while measuring the battery voltage
 - For the D5-Evo Low-Voltage, ensure that the step-down transformer in dwelling is plugged in and working.



First make sure that the moving gate will not pose any danger.

- If the battery voltage drops to below 11.5V, then the battery must be replaced



Before replacing the battery, measure the charging voltage on the battery leads with the battery disconnected. Voltage must be between 13.6V and 13.8V. If not, replace the charger.

18.2. Procedure B - False collision detection

Status light flashes four times to indicate that the number of collisions have exceeded the Collision Counter feature value. LCD screen indicates "Max Collisions"

With the operator in manual mode, check the following and correct if necessary:

- Badly running gate, or something physically obstructing the gate. Check along the entire travel of the gate
- Rack is not pressing down onto pinion
- Bad rack joints
- Wheels are not seized or running badly
- Top guide-rollers are not restricting the gate
- No dirt on rail
- No physical damage to the rail
- Wheel catching side of pinion

With the operator in normal mode, check the following and correct if necessary:

- Gate is not hitting the endstop

Do a general inspection of system, check the following and correct if necessary:

- No ants, dirt, oil or water in and around the DOSS sensor
- DC motor wires for loose connections
- DOSS sensor wire harness is securely plugged into controller
- DOSS sensor is securely clipped into the housing
- If the problem is not solved, replace the DOSS sensor and main controller



Red/black/orange wire = Origin switch, and
Red/black/purple wire = DOSS sensor

19. Manual Operation

19.1. Disengage gearbox/drive

1. Use key to open access door to manual override.

Do not remove the thumbwheel. Removal of the thumbwheel may result in water entering the gearbox and the warrantee will be void.

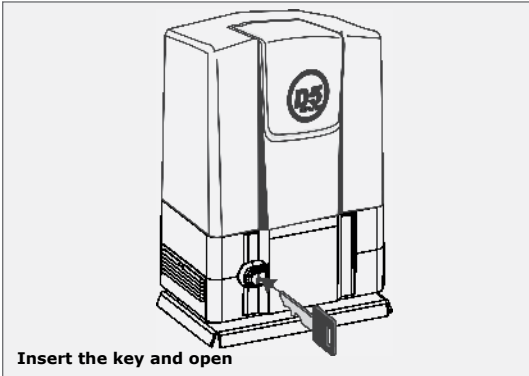

FIGURE 57

2. Rotate thumbwheel clockwise until gearbox releases and gate can be moved manually.
3. If the gearbox must be left in manual mode for an extended period of time for whatever reason, it is recommended that the access door is locked. This secures the cover and prevents access to the inside of the unit, which contains high voltages. It also prevents theft of any components and provides full protection from the elements.

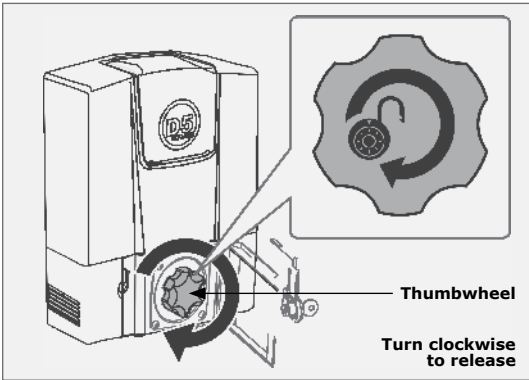

FIGURE 58

19.1. Re-engage gearbox/drive

1. Rotate thumbwheel anti-clockwise until thumbwheel feels loose in the hand. Make sure that the manual override access door can be closed.
2. Slide gate until gearbox/drive engages.

Do not remove the thumbwheel. Removal of the thumbwheel may result in water entering the gearbox and the warrantee will be void.

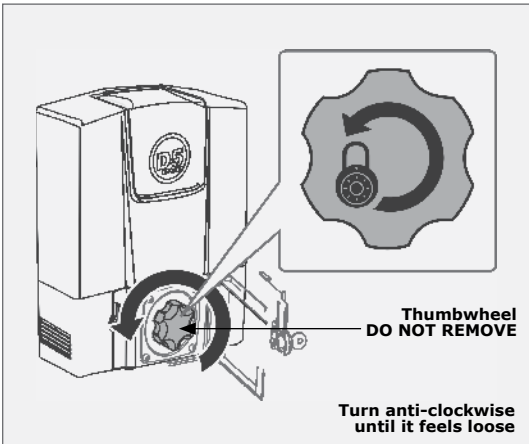

FIGURE 59

20. Installation Handover

Once the installation has been successfully completed and tested, it is important for the installer to explain the operation and safety requirements of the system.

NEVER ASSUME THE USER KNOWS HOW TO SAFELY OPERATE AN AUTOMATED GATE!

Even if the user has used one before, it does not mean he knows how to SAFELY operate it. Make sure that the user fully understands the following safety requirements before finally handing over the site.

The following needs to be understood by the user:

- How to operate the manual release mechanism. **(Show them how by demonstration)**
 - How the obstruction detection and all other safety features work. **(Show them how by demonstration)**
 - All the features and benefits of the operator, i.e. Beams, etc.
 - All the safety considerations associated with operating an automated gate. The user should be able to pass this knowledge on to all other users of the automated system and must be made aware of this responsibility.
- Do not activate the gate operator unless you can see it and can determine that its area of travel is clear of people, pets, or other obstructions
 - **NO ONE MAY CROSS THE PATH OF A MOVING GATE.** Always keep people and objects away from the gate and its area of travel
 - **NEVER LET CHILDREN OPERATE OR PLAY WITH THE GATE CONTROLS,** and do not allow children or pets near the gate area
 - Be careful with moving parts and avoid close proximity to areas where fingers or hands could be pinched
 - Secure all easily-accessible gate operator controls in order to prevent unauthorised use of the gate
 - Keep the automated gate system properly maintained, and ensure that all working areas are free of debris and other objects that could affect the gate operation and safety
 - On a monthly basis, check the obstruction detection system and safety devices for correct operation
 - All repair and service work to this product must be done by a suitably qualified person
 - This product was designed and built strictly for the use indicated in this documentation. Any other use, not expressly indicated here, could compromise the good condition/operation of the product and/or be a source of danger!



Centurion Systems (Pty) Ltd does not accept any liability caused by improper use of the product, or for use other than that for which the automated system was designed. **Ensure that the customer is in possession of the User Guide and that you have completed the installation details in the back of the User Guide.**



Connect with us on:

 facebook.com/CenturionSystems

 YouTube.com/CenturionSystems

 Twitter@askCenturion

Subscribe to the newsletter: www.centsys.com/Subscribe

Call Centurion Systems (Pty) Ltd · South Africa
Head Office: +27 11 699 2400

Call Technical Support: +27 11 699 2481
from 07h00 to 18h00 (UTC+2)

E&OE Centurion Systems (Pty) Ltd reserves the right to change any product without prior notice

All product and brand names in this document that are accompanied by the ® symbol are registered trademarks in South Africa and/or other countries, in favour of Centurion Systems (Pty) Ltd, South Africa.

The CENTURION and CENTSYS logos, all product and brand names in this document that are accompanied by the TM symbol are trademarks of Centurion Systems (Pty) Ltd, in South Africa and other territories; all rights are reserved.

We invite you to contact us for further details



DOC ref - DOC1010D0175 GENERIC-15072015

www.centsys.com